



Cruzber S.A., ES-A14018311
P.I. Las Salinas II, E-14960 Rute
www.cruzber.com

- (E)** **Instrucción de montaje:**
¡Leer primero!
- (GB)** **Assembly instructions:**
Read first!
- (F)** **Instruction de montage:**
Lire en premier!
- (D)** **Montageanleitung:**
Zuerst lesen!
- (PT)** **Instruções de montagem:**
Ler primeiro!
- (PL)** **Instrukcja montażu:**
Najpierw przeczytaj!
- (CZ)** **Montážní návod:**
Čtěte pozorně!
- (HU)** **Szerelési Utasítás:**
Először olvassd el!
- (RO)** **Instructiuni de montaj:**
Intai cititi!
- (HR)** **Detaljne upute**
Prvo pročitati!
- (GR)** **Διαβάστε προσεκτικά τις:**
Οδηγίες Συναρμολόγησης!
- (TR)** **Öncelikli montaj:**
Talimatlarını okuyunuz!
- (RU)** **Инструкции по монтажу:**
Сначала прочитайте!
- (IT)** **Istruzioni di montaggio**
Leggere per primo!

- Barras de acero
- Steel bars
- Barres d'acier
- Stahldachträger
- Barras d'aço
- Belki stalowe
- Ocelové strešní nosiče
- Acél rudak
- Čelične šipke
- Bare din otel
- Μπάρες Σιδερέ
- Çelik barlar
- Стальные поперечины
- Barre d'acciaio

Código Code Code Kode	921- 00x
	Lv 5 2011 - r 7
Modelo Model Modèle Modell	OT 30x20x1,2 G
Lote Lot Lot Lot	<div style="display: inline-block; vertical-align: middle; text-align: left; padding-left: 10px;"> Peso Weight Poids Gewicht </div>
<div style="display: inline-block; vertical-align: middle; text-align: left; padding-left: 10px;"> Kit A: Max. 50kg Kit B: Max. 60kg </div>	
Código Homologación CEE EEC Type Approval Number	
e9*74/483*87/354*3017	

	1°	
	2°	

- (E)** **Contenido embalaje:** ¡Verificar!
- (GB)** **Package content:** Check!
- (F)** **Contenu d'emballage:** Vérifier!
- (D)** **Packungsinhalt:** Überprüfen!
- (PT)** **Contéudo embalagem:** Verificar!
- (PL)** **Zawartość opakowania:** sprawdzić!
- (CZ)** **Obsah balení:** Zkontrolujte!
- (HU)** **Csomag tartalma:** Ellenőrizd!
- (RO)** **Pachetul contine:** Verificati!
- (HR)** **Sadržaj paketa:** Provjeri!
- (GR)** **Ελέγξτε το περιεχόμενο:** του πακέτου!
- (TR)** **Paket içeriğini:** Control ediniz!
- (RU)** **Содержание упаковки:** Проверьте!
- (IT)** **Contenuto della confezione:** Controllare!

x 1	x 1	x 2	x 2

Código Code		↔		kg	Lote Lot
921-000	OT-105 (823-203)	105 cm	81,5 cm (825-204)	3,64 kg	02/07
921-001	OT-115 (823-213)	115 cm	95 cm (825-214)	3,96 kg	02/07

Código
Code
Code
Kode

921-00x

Lv 5 2011 - r7

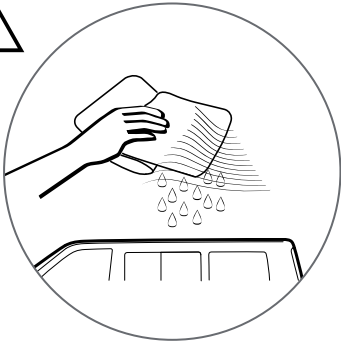

Importante!
Important!
Important!
Wichtig!

- E** Estas barras tienen que usarse con Kits de fijación Cruz!
- GB** Bars must be used with Cruz fixation Kits!
- F** Les barres devront être utilisées avec les Kits de fixation Cruz!
- D** Die Dachlsträger nur mit Cruz Stützfuß-Kits befestigen!
- PT** As barras devem ser utilizadas com os Kits de fixação Cruz!
- PL** Belki muszą być stosowane z elementami mocującymi firmy Cruz!
- CZ** Tento nosič musí být používán s fixačním kitem Cruz!
- HU** A rudákat csak Cruz rögzítő készlettel szabad használni!
- RO** Barele trebuie utilizate cu Kit-uri de fixare Cruz!
- HR** Šipke moraju biti korištene sa Cruz kitovima za montažu!
- GR** Το αξεσουάρ αυτό θα πρέπει να χρησιμοποιείται αποκλειστικά στα συστήματα μπαρών της Cruz!
- TR** Bu barlar mutlak Cruz montaj kiti!
- RU** Поперечины должны быть использованы со специальным крепежным комплектом Cruz!
- IT** Questa bare deve essere utilizzato solo con il kit di fissaggio Cruz!

1

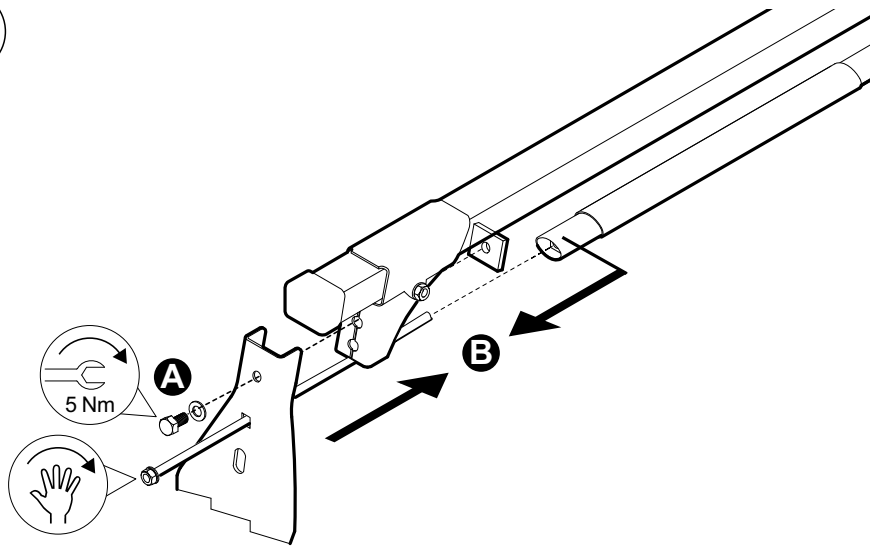

2



3

