

# Thule System Kit 2066

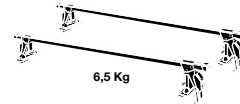

**FORD Courier, 2-dr, 99-  
FORD Ranger, 2-dr, 00-  
MAZDA Bravo, 2-dr, 99-  
MAZDA B-Serie, 2-dr, 99-**

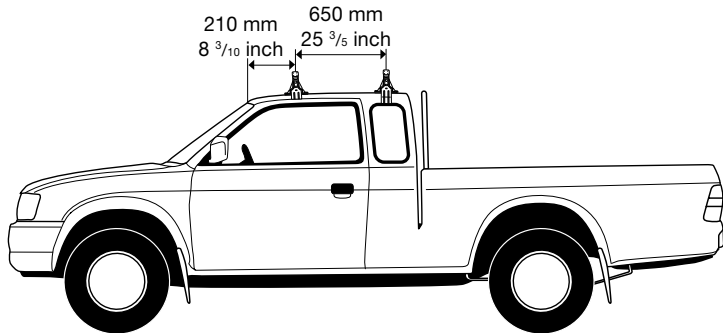
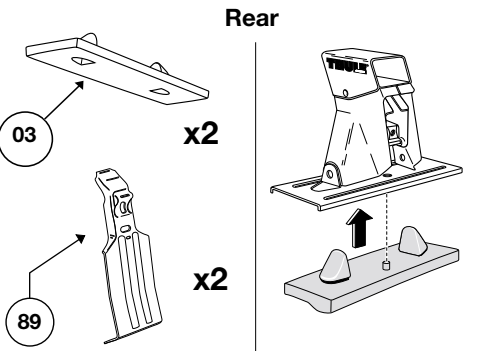
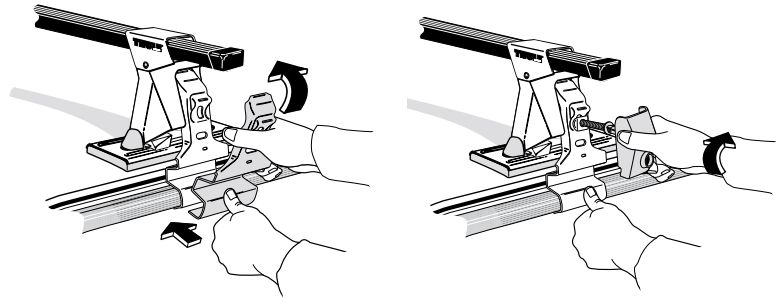
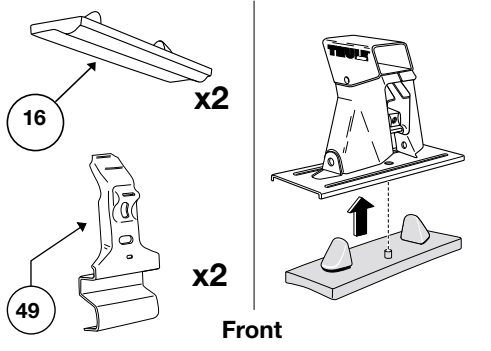

**FORD Courier, 4-dr, 99-  
FORD Ranger, 4-dr, 00-  
MAZDA Bravo, 4-dr, 99-  
MAZDA B-Serie, 4-dr, 99-**

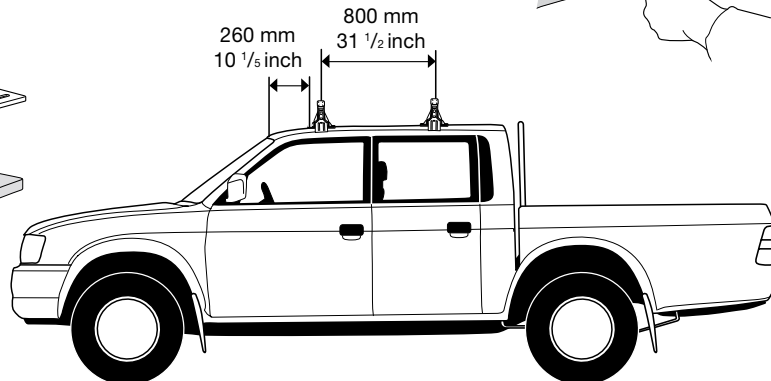
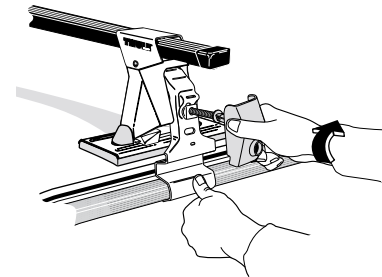
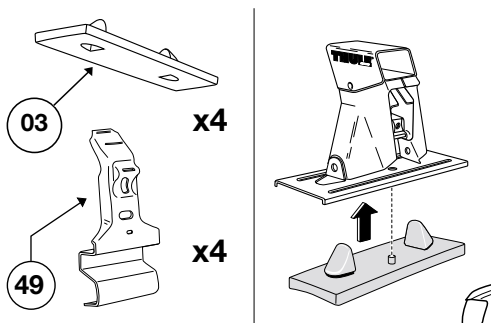

	Front	Rear
<b>FORD Courier 2-dr</b>	1010 mm ± 5 mm 39 3/4 inch ± 1/4 inch	1000 mm ± 5 mm 39 2/5 inch ± 1/4 inch
<b>FORD Ranger 2-dr</b>	1010 mm ± 5 mm 39 3/4 inch ± 1/4 inch	1020 mm ± 5 mm 40 1/8 inch ± 1/4 inch
<b>MAZDA Bravo 2-dr</b>	1010 mm ± 5 mm 39 3/4 inch ± 1/4 inch	1000 mm ± 5 mm 39 2/5 inch ± 1/4 inch
<b>MAZDA B-Serie 2-dr</b>	1010 mm ± 5 mm 39 3/4 inch ± 1/4 inch	1020 mm ± 5 mm 40 1/8 inch ± 1/4 inch



	Front	Rear
<b>FORD Courier 4-dr</b>	1010 mm ± 5 mm 39 3/4 inch ± 1/4 inch	1000 mm ± 5 mm 39 2/5 inch ± 1/4 inch
<b>FORD Ranger 4-dr</b>	1010 mm ± 5 mm 39 3/4 inch ± 1/4 inch	1020 mm ± 5 mm 40 1/8 inch ± 1/4 inch
<b>MAZDA Bravo 4-dr</b>	1010 mm ± 5 mm 39 3/4 inch ± 1/4 inch	1000 mm ± 5 mm 39 2/5 inch ± 1/4 inch
<b>MAZDA B-Serie 4-dr</b>	1010 mm ± 5 mm 39 3/4 inch ± 1/4 inch	1020 mm ± 5 mm 40 1/8 inch ± 1/4 inch