

# Atera SIGNO

Mercedes Benz  
CKL-Klasse (C117) 04/2013 – 05/2019

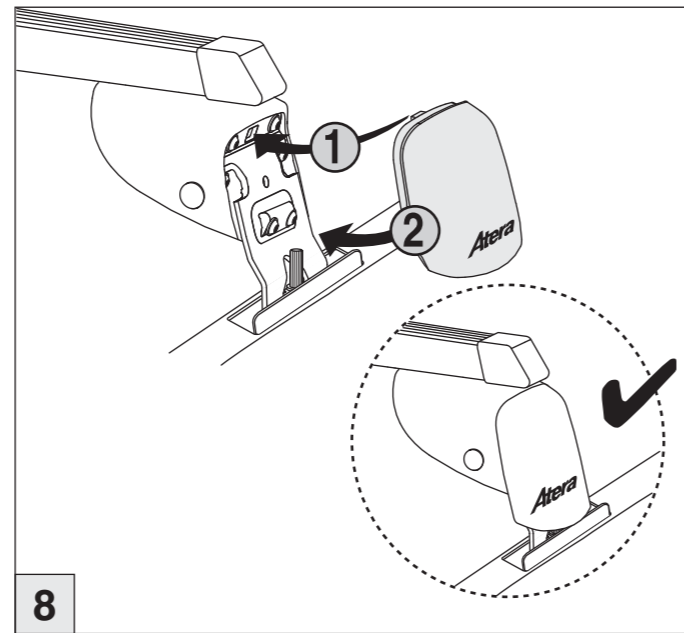

nur bei / only for Part-No.: 045 189

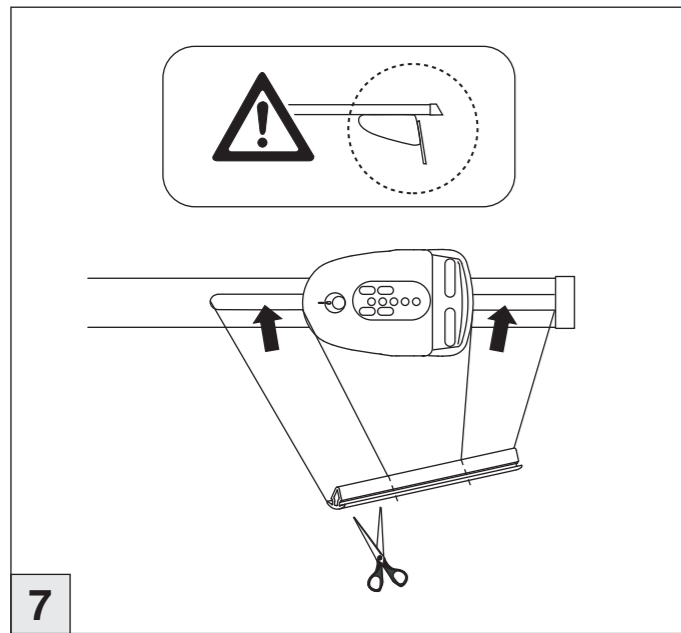
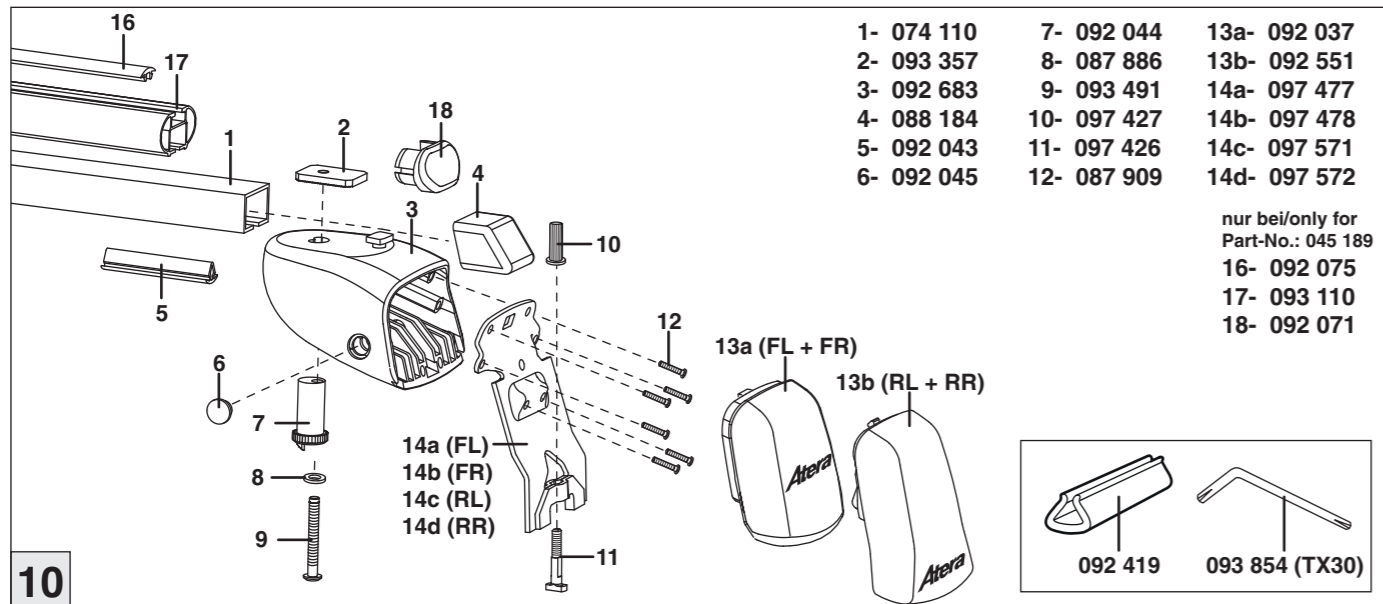
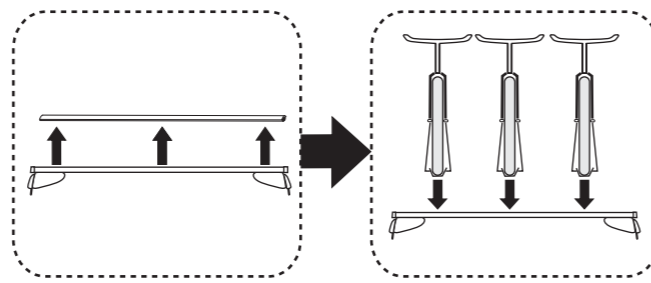
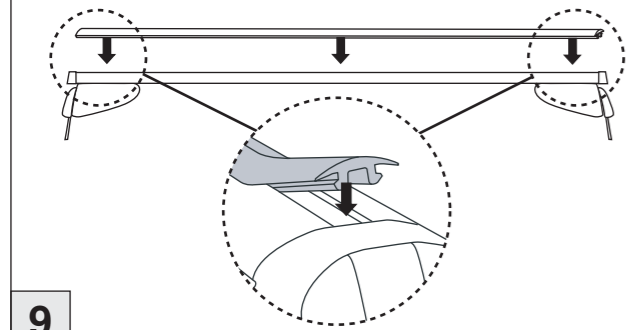

# Atera SIGNO

Mercedes Benz  
CLA-Klasse (C117) 04/2013 – 05/2019

Art.Nr. / Part-No. : 044 189  
Art.Nr. / Part-No. : 045 189

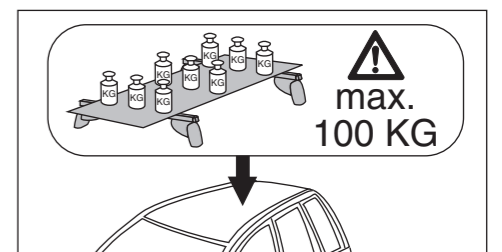
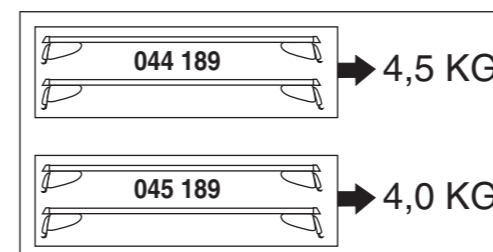
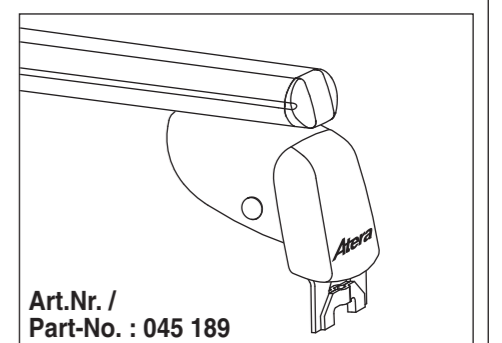
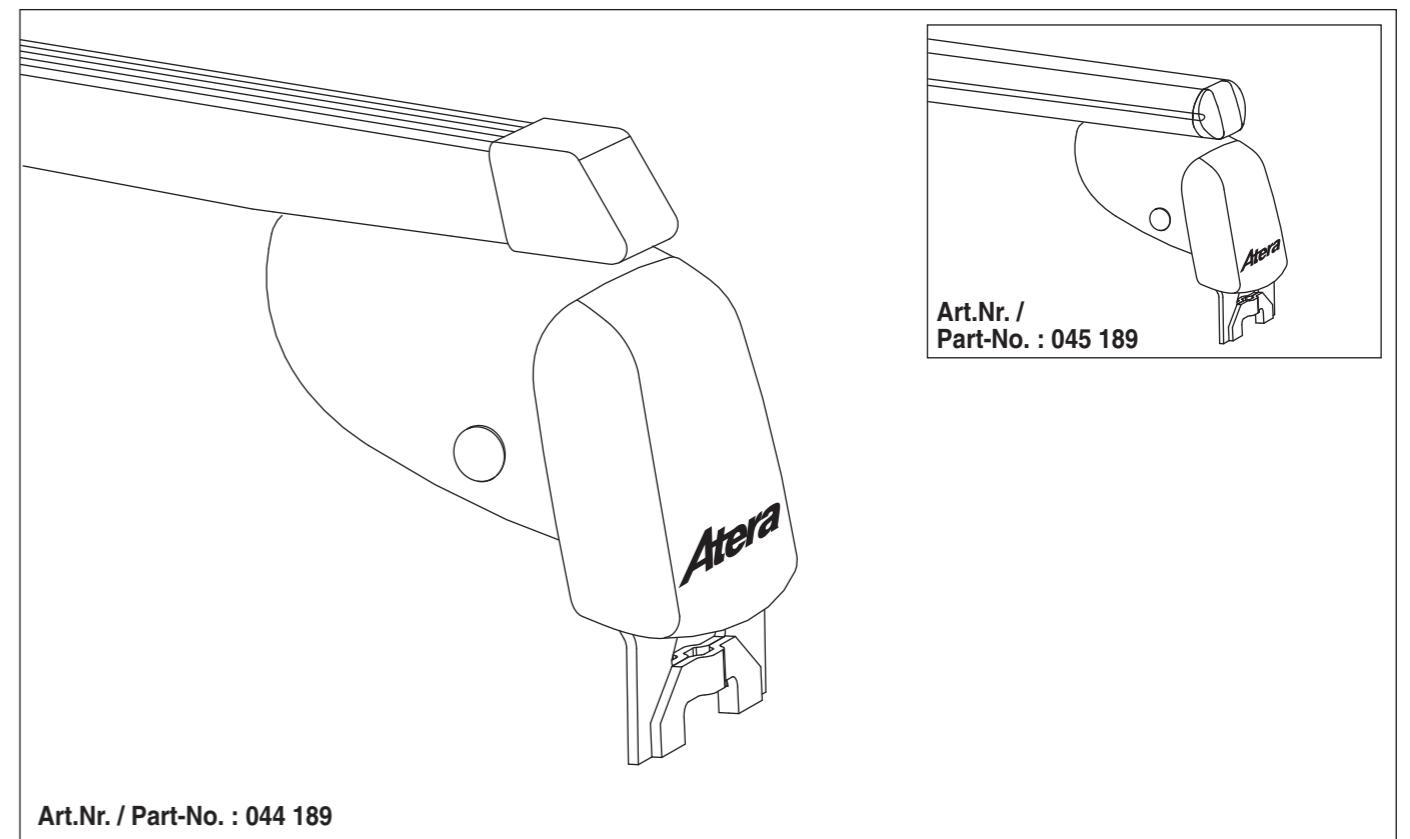

**Atera**  
Atera GmbH  
Im Herrach 1  
D-88299 Leutkirch  
Internet: www.atera.de



# Atera SIGNO

Mercedes Benz  
CKL-Klasse (C117) 04/2013 – 05/2019

# Atera SIGNO

Mercedes Benz  
CKL-Klasse (C117) 04/2013 – 05/2019

