

Atera SIGNO

Mazda CX3 06/2015-

Atera SIGNO

Mazda CX3 06/2015 -

Part-No. : 044 325
Part-No. : 045 325

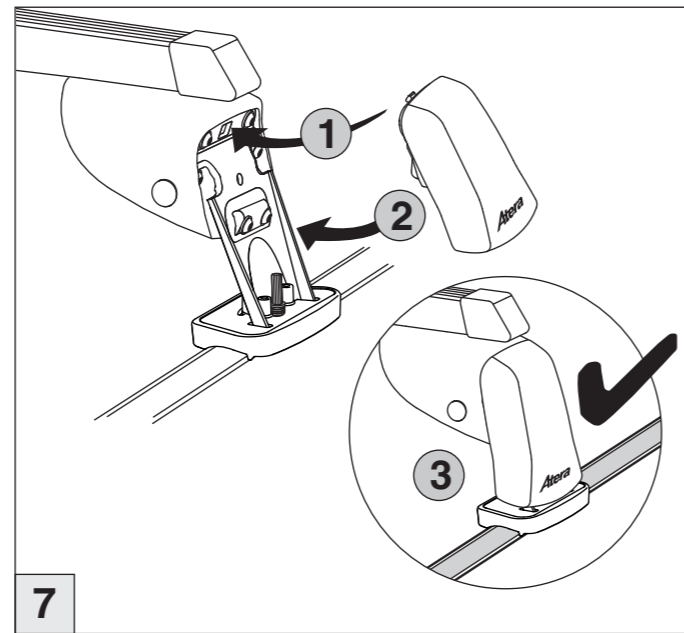
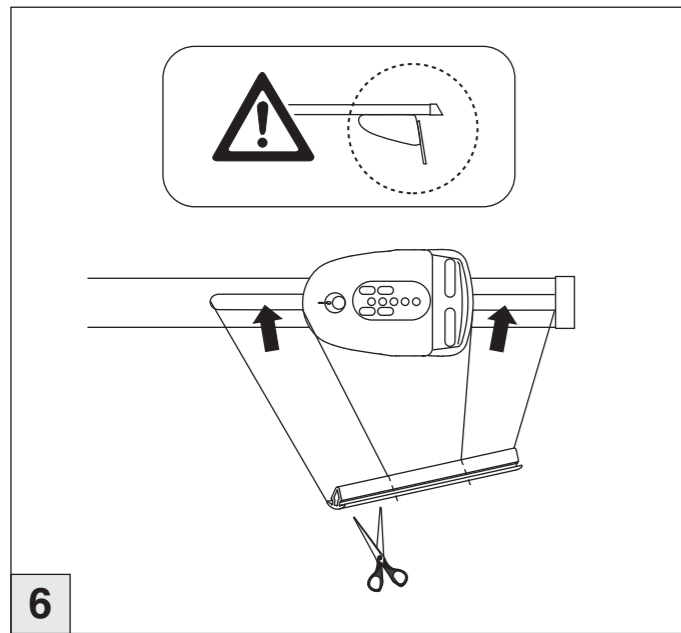

nur bei / only for Part-No.: 045 325

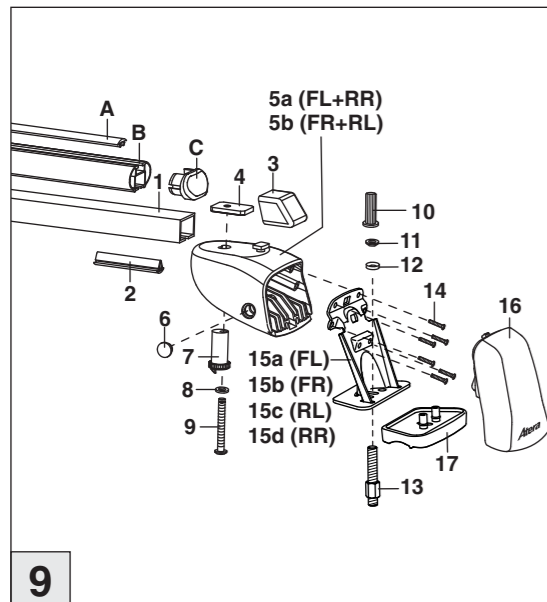
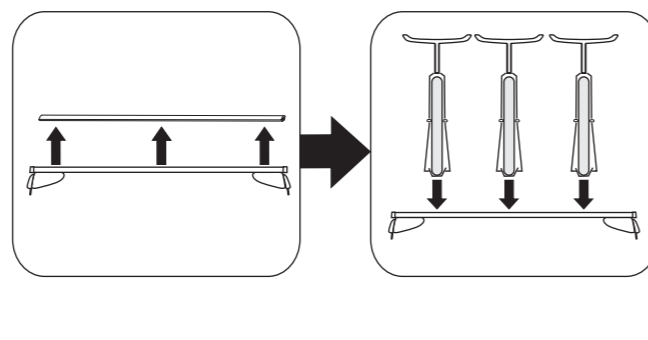
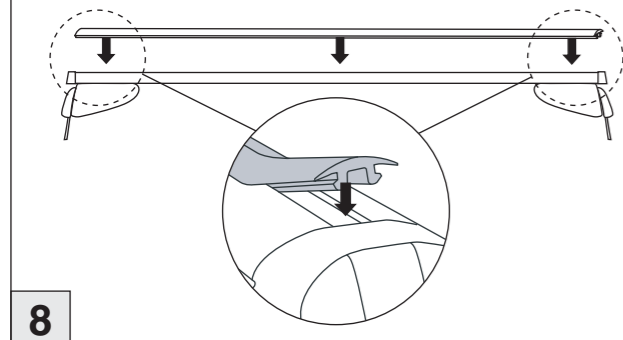

- nur bei Art.Nr.: 045 325
only for part no.: 045 325
- | | |
|---------------|-----------------|
| A- 9919700065 | 11- 9910700030 |
| B- 9945700111 | 12- 9910700077 |
| C- 9918700253 | 13- 9903700006 |
| | 14- 9908700010 |
| | 15a- 9949700600 |
| | 15b- 9949700601 |
| | 15c- 9949701603 |
| | 15d- 9949701602 |
| | 16- 9918700472 |
| | 17- 9918700654 |
- | | |
|----------------|------------------|
| 1- 9945700090 | 9904700387(TX30) |
| 2- 9919700062 | 9904701197 (SW8) |
| 3- 9945700105 | 9908700153 |
| 4- 9912700051 | 9923700165 |
| 5a- 9918700526 | |
| 5b- 9918700527 | |
| 6- 9918700250 | |
| 7- 9918700249 | |
| 8- 9910700004 | |
| 9- 9908700231 | |
| 10- 9912700100 | |

= ✓

Bohren Sie vor der Erstmontage des Dachtragers in die beiden Dachleisten des Fahrzeuges je zwei Locher. Wir empfehlen die dazu notwendigen Arbeiten in einer Fachwerkstatt durchführen zu lassen. Siehe auch Zusatzblatt 992570050500.

Before mounting the roofrack, drill two holes into each of the roof trims. We recommend that you have the necessary work carried out by a specialist workshop. See also extra sheet 992570050500.

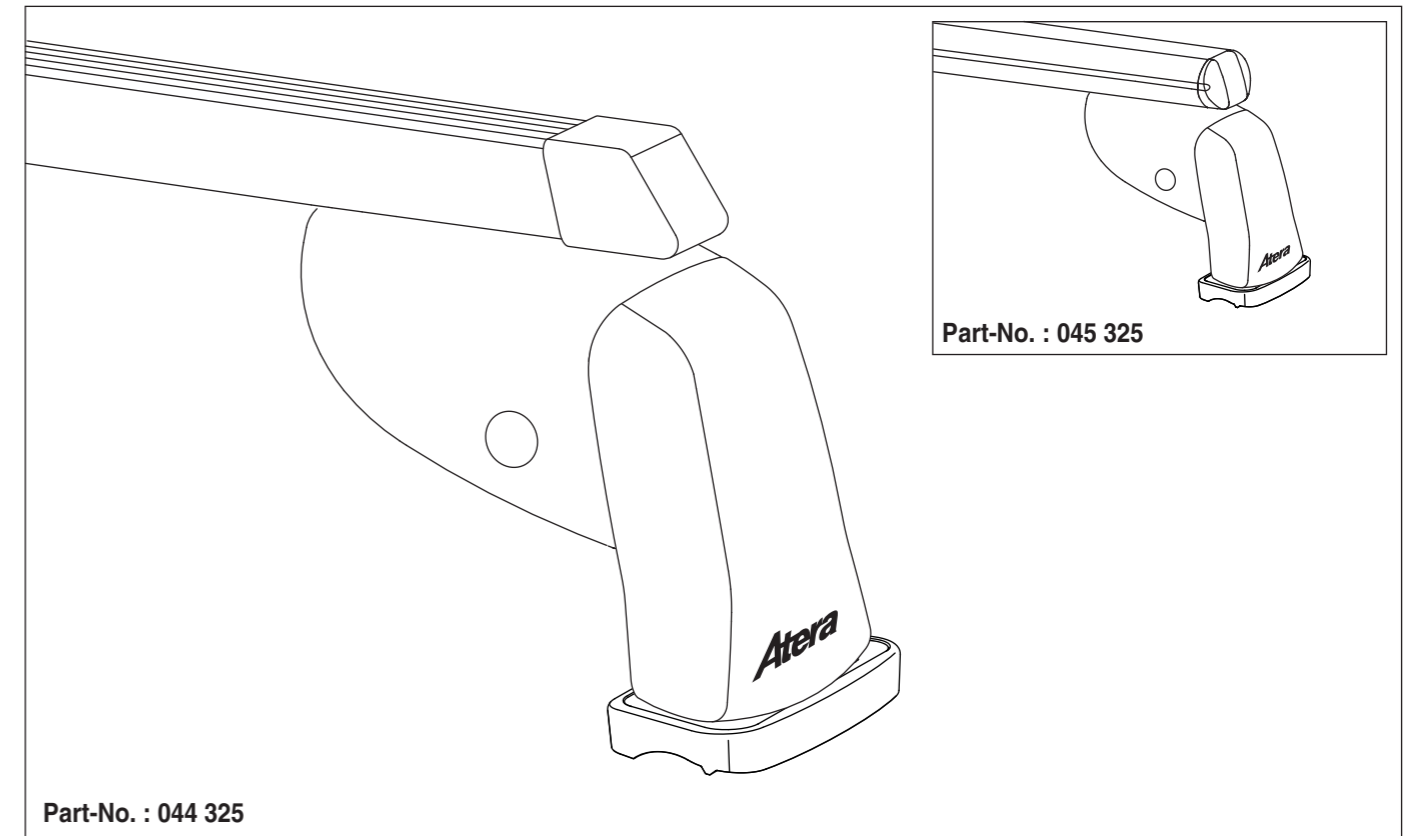

044 325 (Stahl) (Steel)		5,0 kg
045 325 (Aluminium) (Aluminium)		4,5 kg

max. 50 kg

max. kg?



Atera SIGNO

Mazda CX3 06/2015-

Atera SIGNO

Mazda CX3 06/2015-

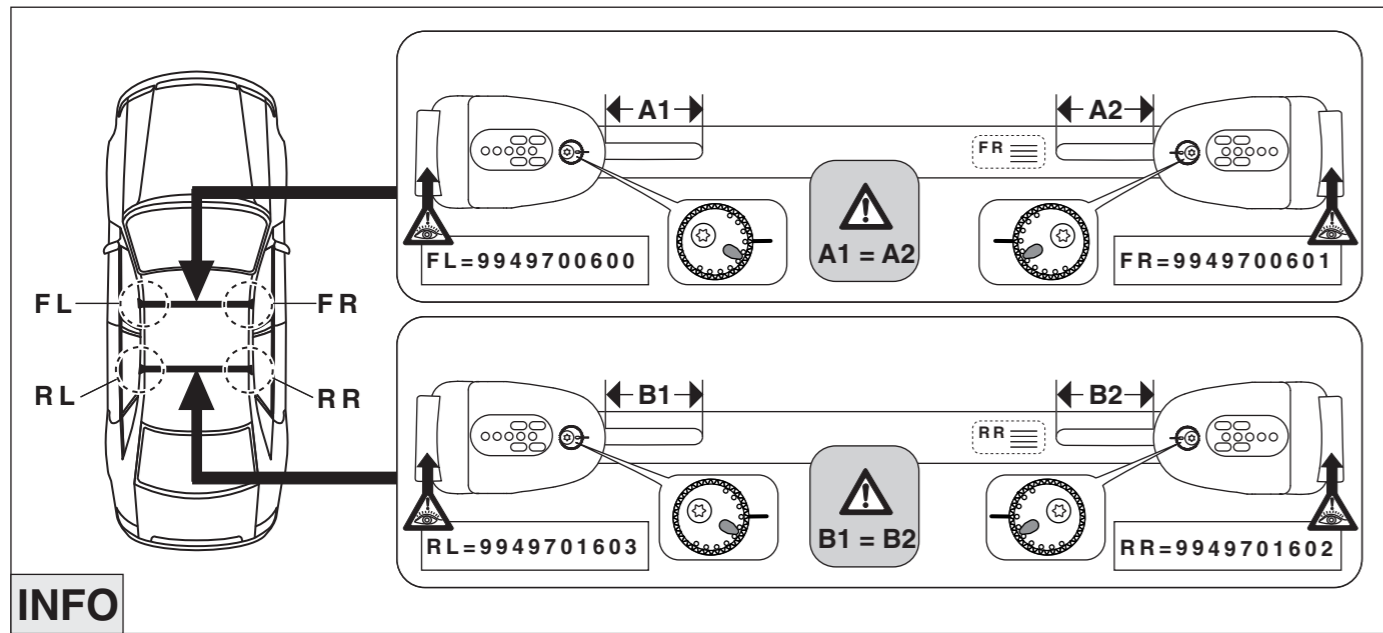

INFO

