

# Atera® SIGNO

Daewoo  
Kalos (5-türig/doors/portes) 9/2002–

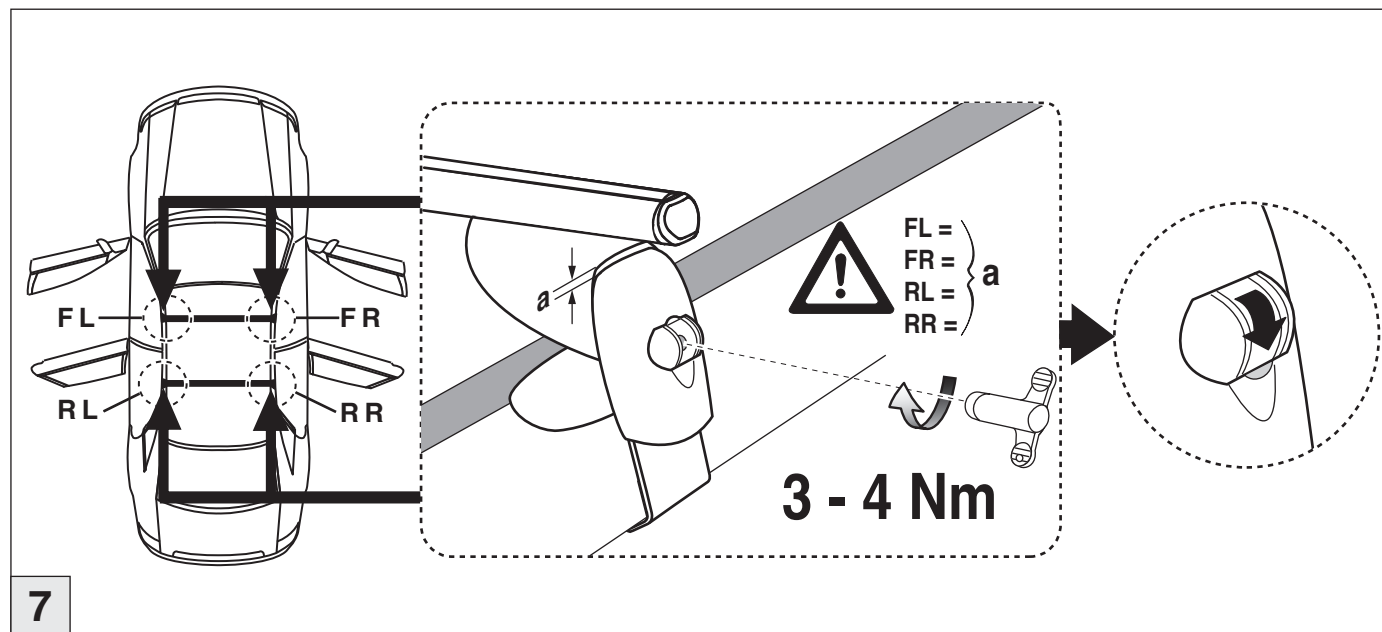

7

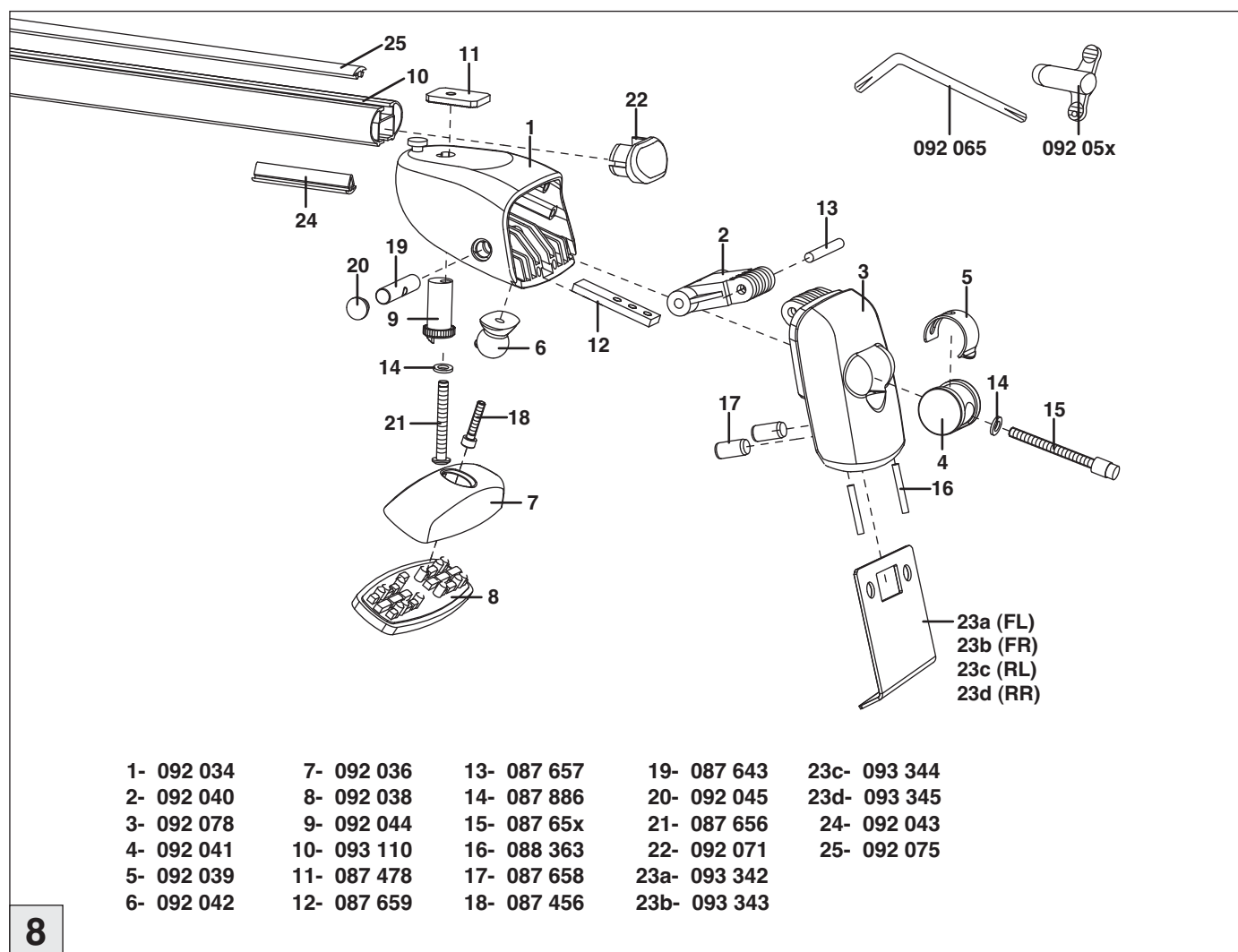

8

**Atera®**  
MADE IN GERMANY

Atera GmbH  
Postfach 2240  
D-88192 Ravensburg  
Telefon 07 51 - 76 04-0  
Telefax 07 51 - 76 04-76  
E-Mail: info@atera.de

# Atera® SIGNO

Daewoo  
Kalos 5-türig/doors/portes 9/2002–  
Part-No. : 045 033

- D** Benutzer-Information  
Vor Gebrauch des Trägersystems/Zubehörs sorgfältig und vollständig lesen!
- GB** User information  
Please read all instructions carefully before using the carrying system/accessories!
- F** Informations destinées à l'utilisateur  
Veuillez lire soigneusement toutes les instructions avant l'utilisation du système de porte-charge/des accessoires!
- NL** Gebruikerinformatie  
Voor gebruik van het dragersysteem en/of de accessoires zorgvuldig en volledig lezen!
- DK** Brugerinformation  
Læs betjeningsvejledningen grundigt igennem inden ibrugtagning.
- FIN** Ohjeita käyttäelle  
Lue ohje huolellisesti ja kokonaan ennen kattotelinejärjestelmän/lisävarusteiden käyttöönottoa.
- I** Informazioni per l'utente  
Prima dell'uso del sistema di trasporto/dell'accessorio leggere attentamente tutte le indicazioni!
- ES** Información para usuarios  
¡Leer cuidadosamente las instrucciones completas antes de usar el sistema portador / los accesorios!

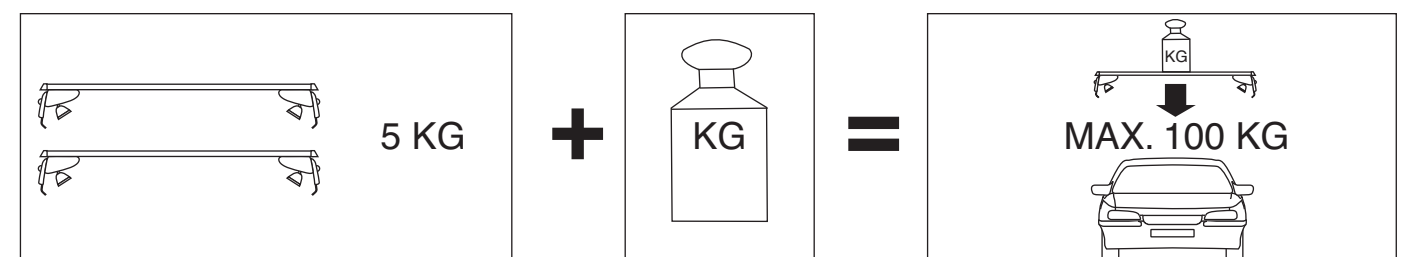
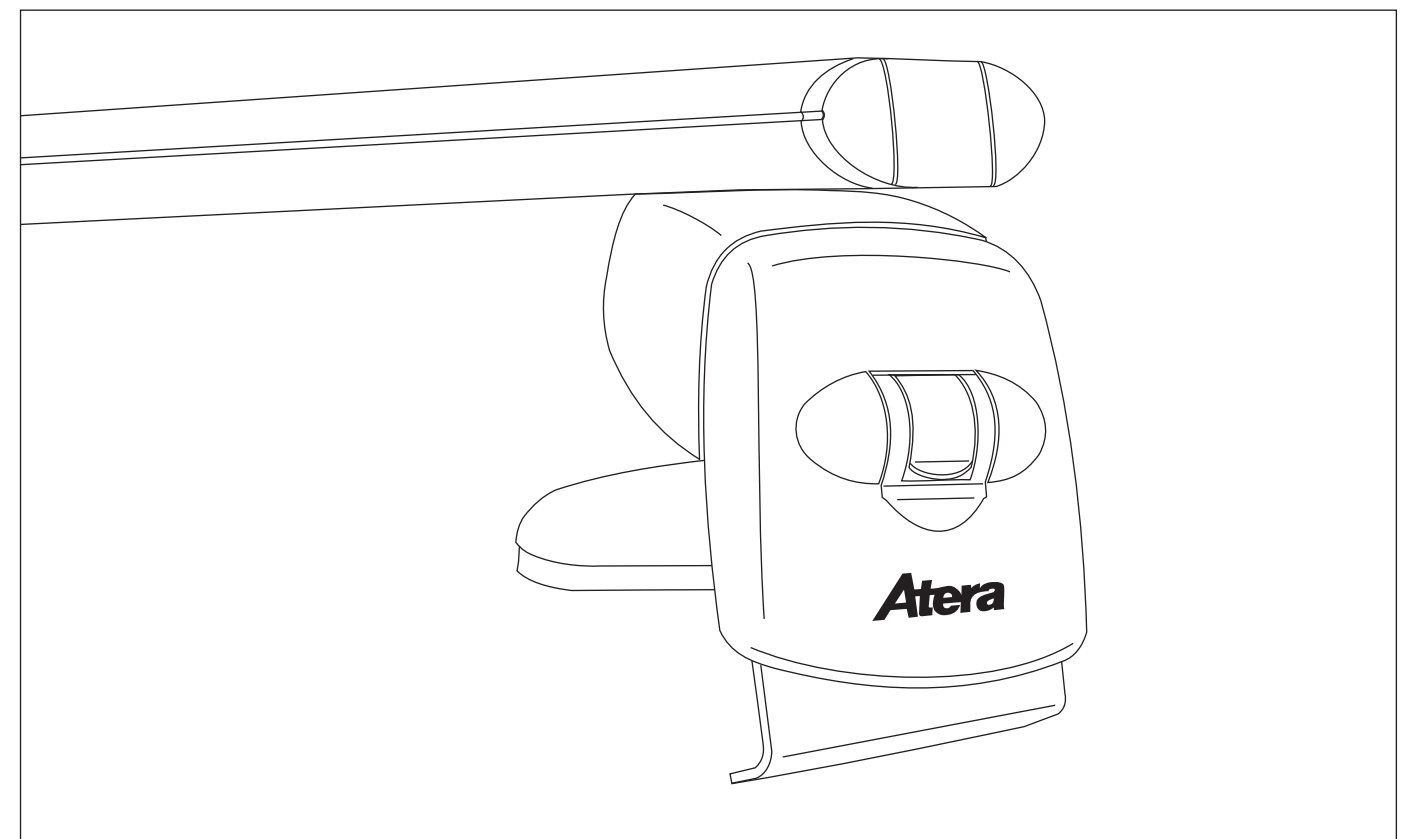

# Atera® SIGNO

Daewoo  
Kalos (5-türig/doors/portes) 9/2002-

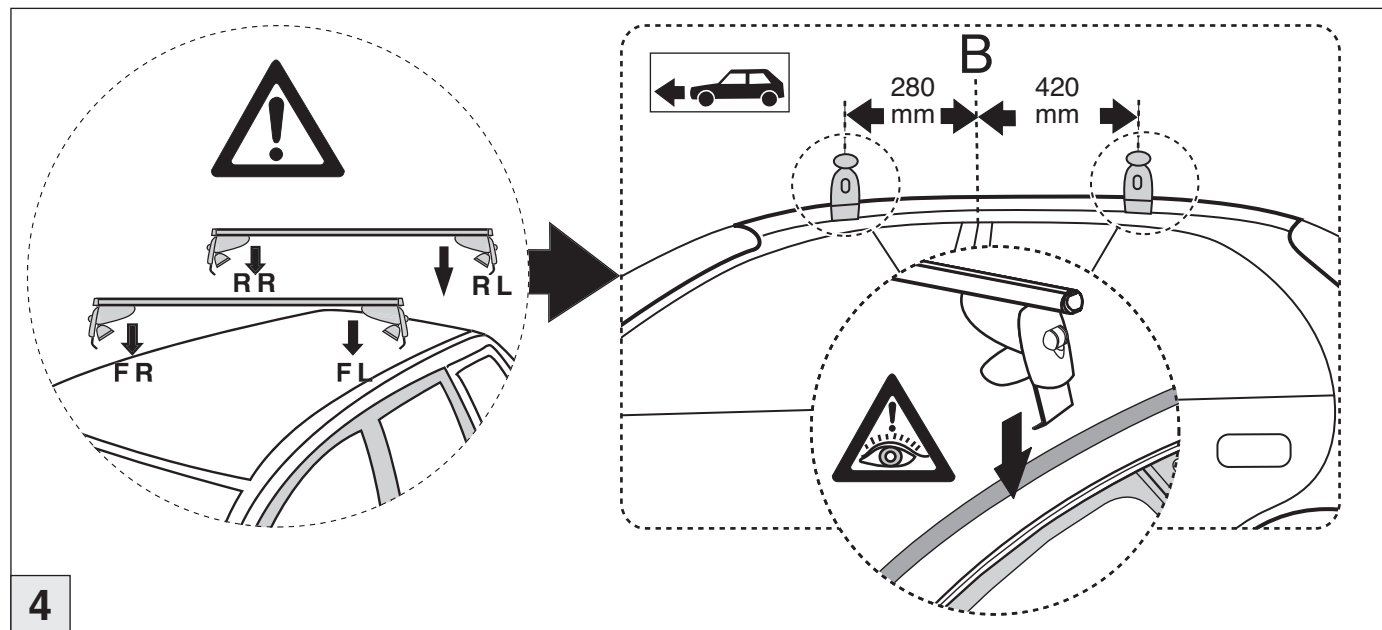
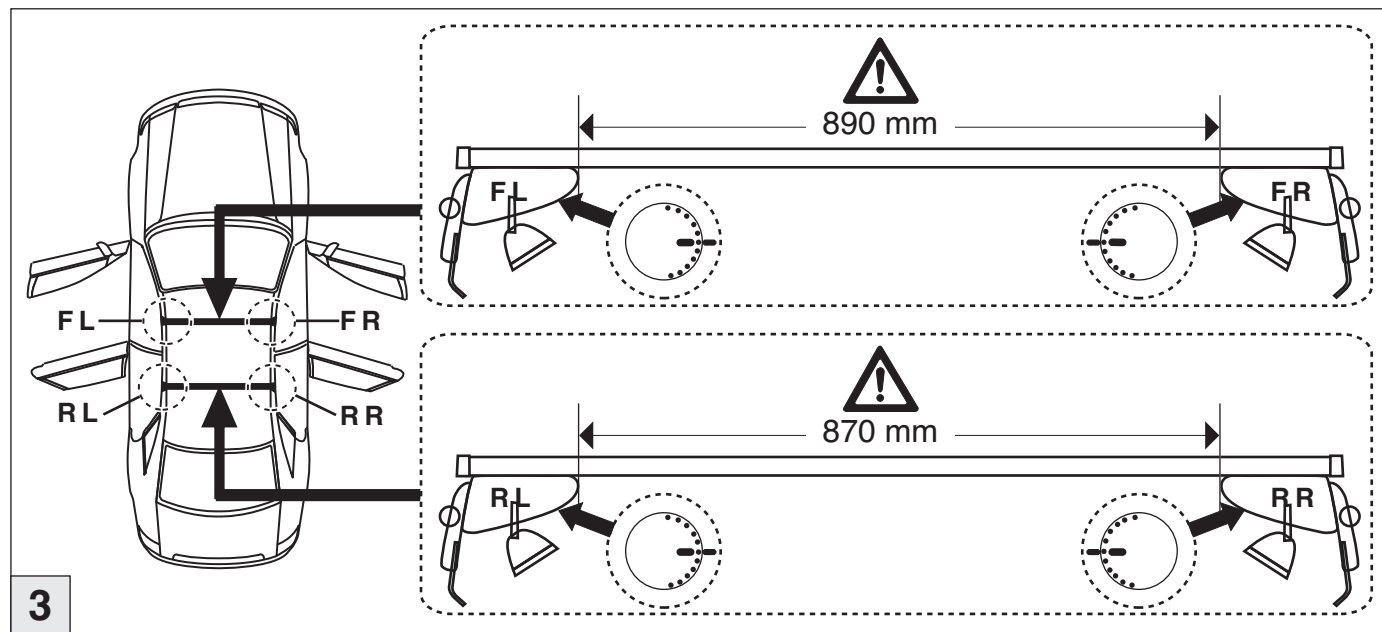
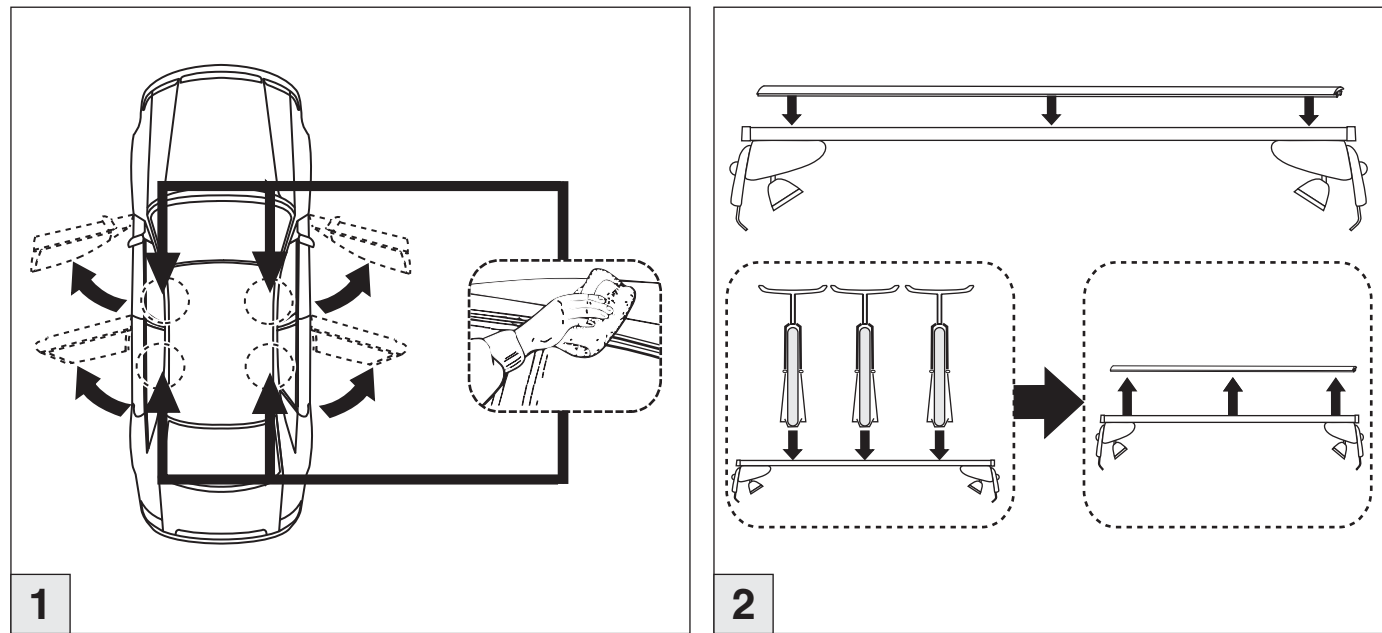

# Atera® SIGNO

Daewoo  
Kalos (5-türig/doors/portes) 9/2002-

