

YAKIMA

KeelOver

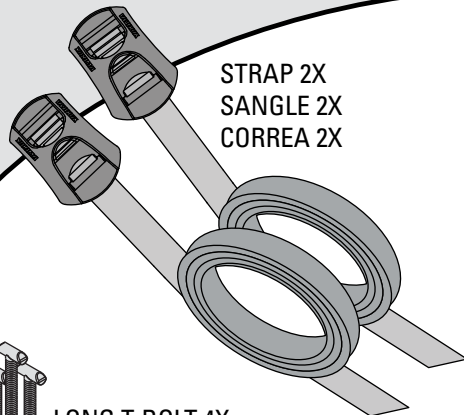

STRAP 2X
SANGLE 2X
CORREA 2X



LONG T-BOLT 4X
BOULON EN T LONG 4X
PERNO T LARGO 4X

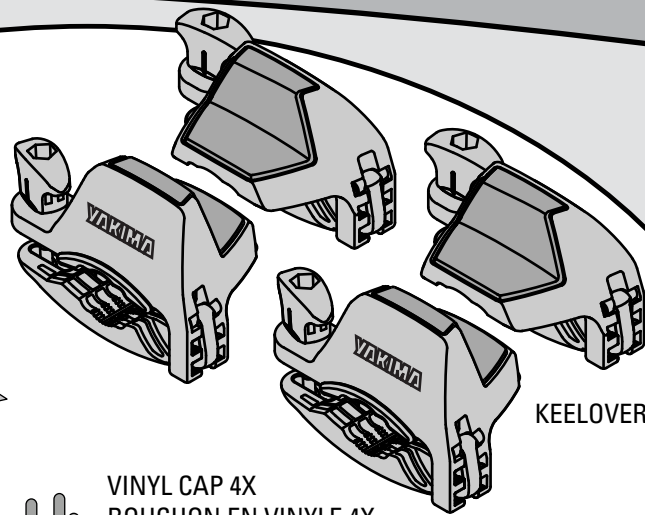

KEELOVER 4X



VINYL CAP 4X
BOUCHON EN VINYLE 4X
TAPÓN DE VINILO 4X

Bow-Stern Tie Down • Arrimage de Proue – Poupe • Amarre de Proa/Popa

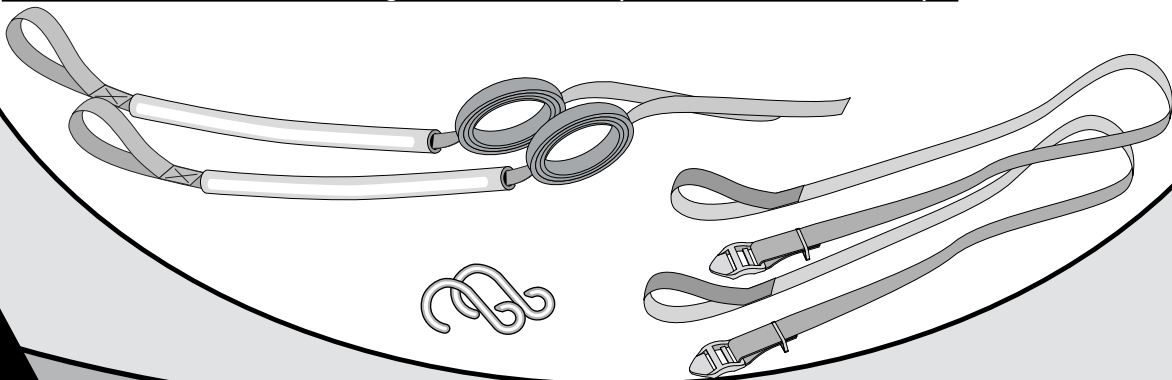

IMPORTANT WARNING

IT IS CRITICAL THAT ALL YAKIMA RACKS AND ACCESSORIES BE PROPERLY AND SECURELY ATTACHED TO YOUR VEHICLE. IMPROPER ATTACHMENT COULD RESULT IN AN AUTOMOBILE ACCIDENT, AND COULD CAUSE SERIOUS BODILY INJURY OR DEATH TO YOU OR TO OTHERS. YOU ARE RESPONSIBLE FOR SECURING THE RACKS AND ACCESSORIES TO YOUR CAR, CHECKING THE ATTACHMENTS PRIOR TO USE, AND PERIODICALLY INSPECTING THE PRODUCTS FOR ADJUSTMENT, WEAR, AND DAMAGE. THEREFORE, YOU MUST READ AND UNDERSTAND ALL OF THE INSTRUCTIONS AND CAUTIONS SUPPLIED WITH YOUR YAKIMA PRODUCT PRIOR TO INSTALLATION OR USE. IF YOU DO NOT UNDERSTAND ALL OF THE INSTRUCTIONS AND CAUTIONS, OR IF YOU HAVE NO MECHANICAL EXPERIENCE AND ARE NOT THOROUGHLY FAMILIAR WITH THE INSTALLATION PROCEDURES, YOU SHOULD HAVE THE PRODUCT INSTALLED BY A PROFESSIONAL INSTALLER.

AVERTISSEMENT IMPORTANT

IL EST ESSENTIEL QUE TOUTS LES SUPPORTS ET ACCESSOIRES YAKIMA SOIENT FIXÉS ET ATTACHÉS SOLIDEMENT À VOTRE VÉHICULE. UNE ATTACHE INADÉQUATE PEUT CAUSER UN ACCIDENT DU VÉHICULE ET DES BLESSURES GRAVES OU MORTELLES POUR VOUS OU POUR LES AUTRES. IL VOUS INCOMBE DE FIXER LES SUPPORTS ET ACCESSOIRES À VOTRE VÉHICULE, DE VÉRIFIER LES ATTACHES AVANT D'UTILISER LE DISPOSITIF, DE VÉRIFIER RÉGULIÈREMENT QUE LE PRODUIT EST AJUSTÉ, ET QU'IL N'EST PAS USÉ OU ENDOMMAGÉ. IL VOUS FAUT DONC LIRE ET COMPRENDRE TOUTES LES DIRECTIVES ET MISES EN GARDE FOURNIES AVEC VOTRE PRODUIT YAKIMA AVANT DE L'INSTALLER OU DE L'UTILISER. SI TOUTES LES INSTRUCTIONS ET MISES EN GARDE NE SONT PAS COMPRIS, OU SI L'ON N'A AUCUNE EXPÉRIENCE EN MÉCANIQUE ET QUE L'ON N'EST PAS TRÈS FAMILIER AVEC LES PROCÉDURES D'INSTALLATION, FAIRE INSTALLER LE PRODUIT PAR UN INSTALLATEUR PROFESSIONNEL COMME UN GARAGISTE QUALIFIÉ OU RÉPARATEUR DE CARROSSERIE.

ADVERTENCIA IMPORTANTE

ES FUNDAMENTAL QUE TODOS LOS PORTAEQUIPAJES Y ACCESORIOS YAKIMA ESTÉN FIJADOS DE MANERA CORRECTA Y SEGURA AL VEHÍCULO. UNA INSTALACIÓN DEFICIENTE PODRÍA CAUSAR UN ACCIDENTE AUTOMOVILÍSTICO Y PROVOCAR HERIDAS GRAVES O LA MUERTE A USTED O A TERCEROS. USTED ES RESPONSABLE DE LA FIJACIÓN SEGURA DE LOS PORTAEQUIPAJES Y ACCESORIOS AL VEHÍCULO. VERIFICANDO LAS UNIONES Y AMARRS ANTES DE UTILIZARLOS E INSPECCIONANDO PERIÓDICAMENTE EL AJUSTE DE LOS PRODUCTOS, SU DESGASTE Y POSIBLES DAÑOS. POR ELLO, DEBE LEER Y COMPRENDER TODAS LAS INSTRUCCIONES Y ADVERTENCIAS QUE VIENEN CON LOS PRODUCTOS YAKIMA ANTES DE INSTALARLOS O USARLOS. SI NO ENTIENDE TODAS LAS INSTRUCCIONES Y ADVERTENCIAS, O NO TIENE EXPERIENCIA EN MECÁNICA O NO ESTÁ FAMILIARIZADO CON LOS PROCEDIMIENTOS DE INSTALACIÓN, HAGA INSTALAR EL PRODUCTO POR UN INSTALADOR PROFESIONAL.

PART# 1034210 Rev.B

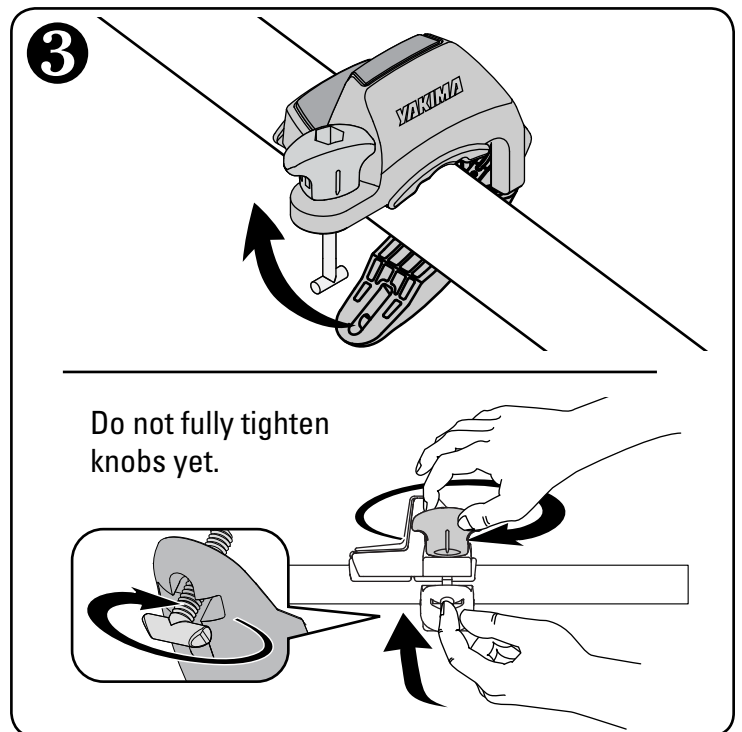
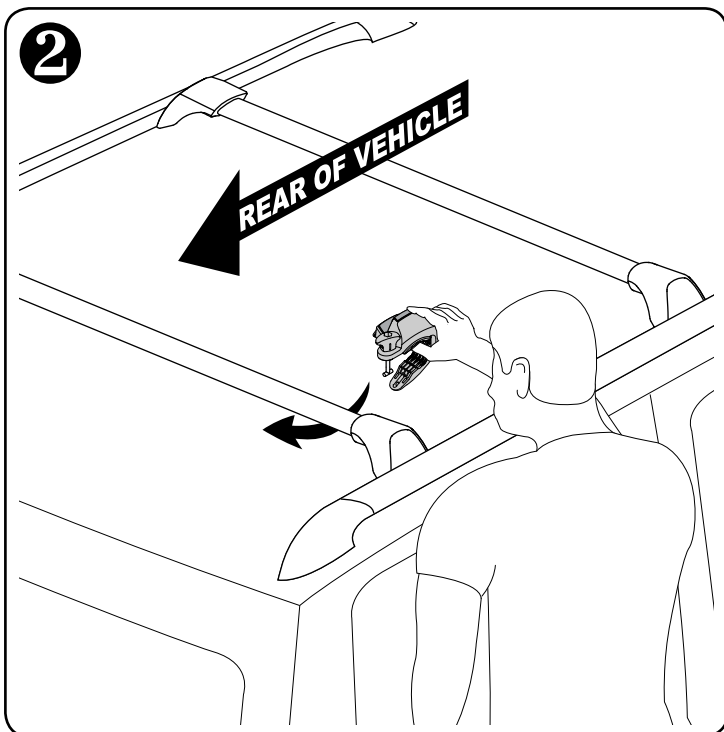
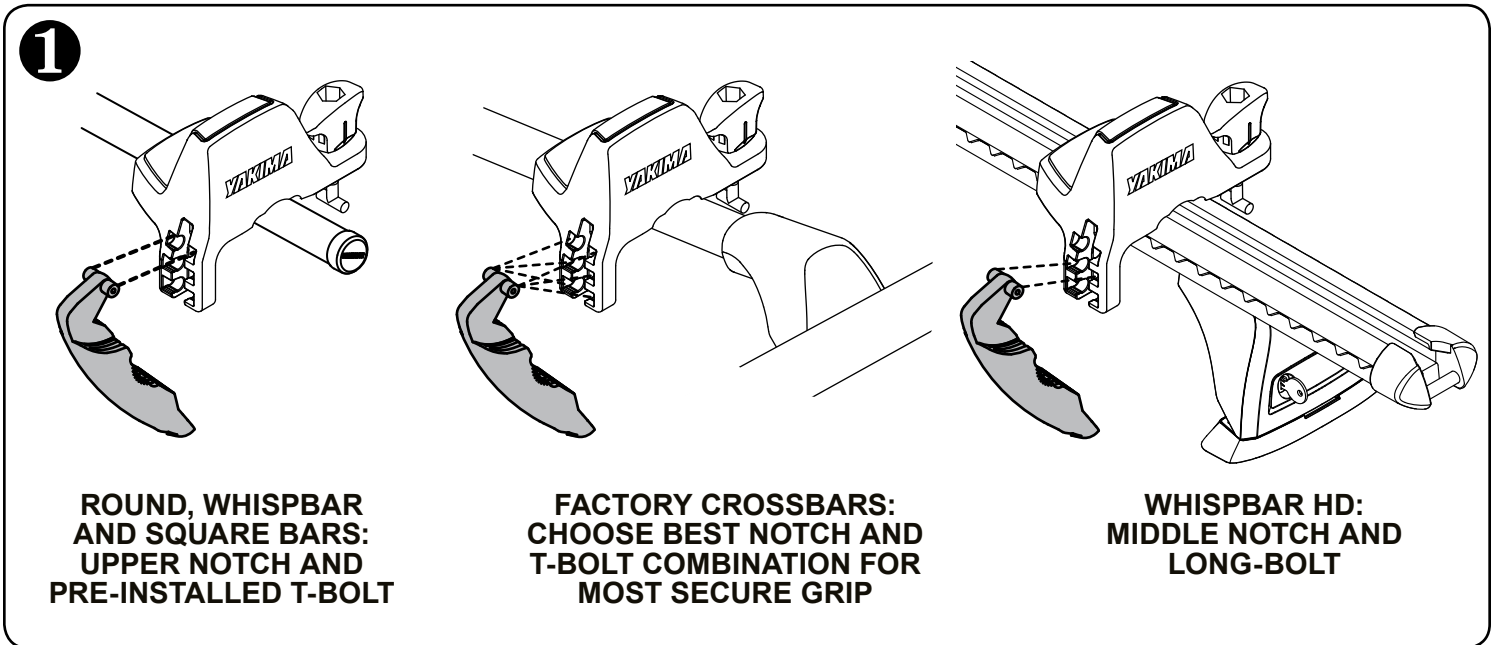
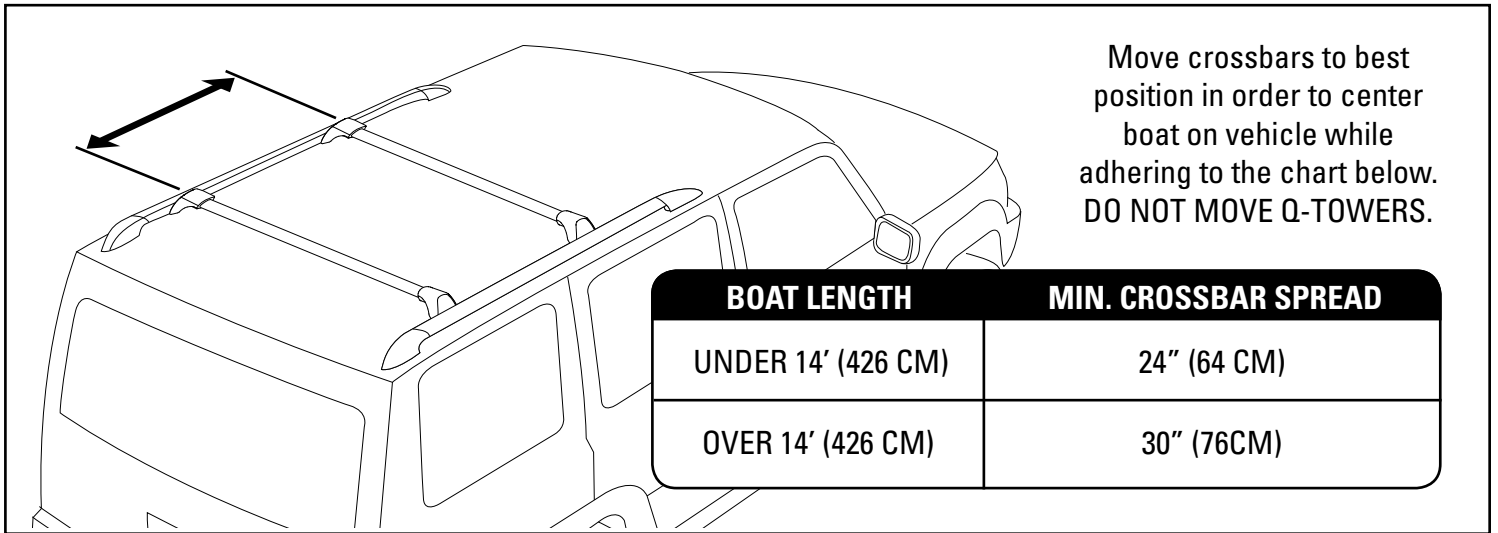

4 Mount brackets at end of bars.

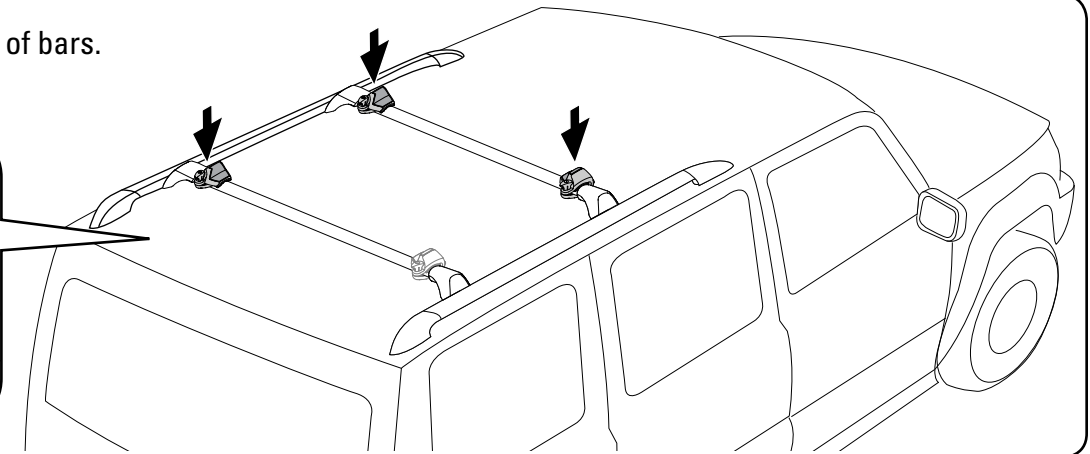
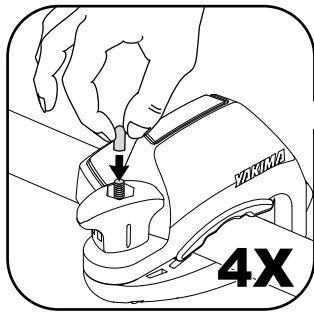

BIG boat?

Need just a few inches more? Flipping the brackets can get you up to 3 extra inches.

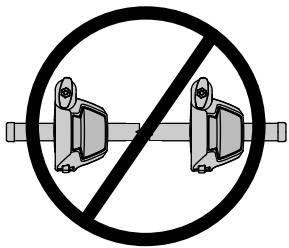
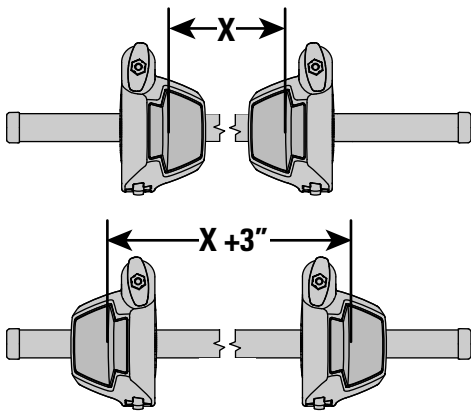

Mixing directions of the brackets in application is not acceptable!

BIG boat?

Need more than a few inches? A Yakima base system will allow for the KeelOver to be installed outside of the towers to accommodate bigger boats.

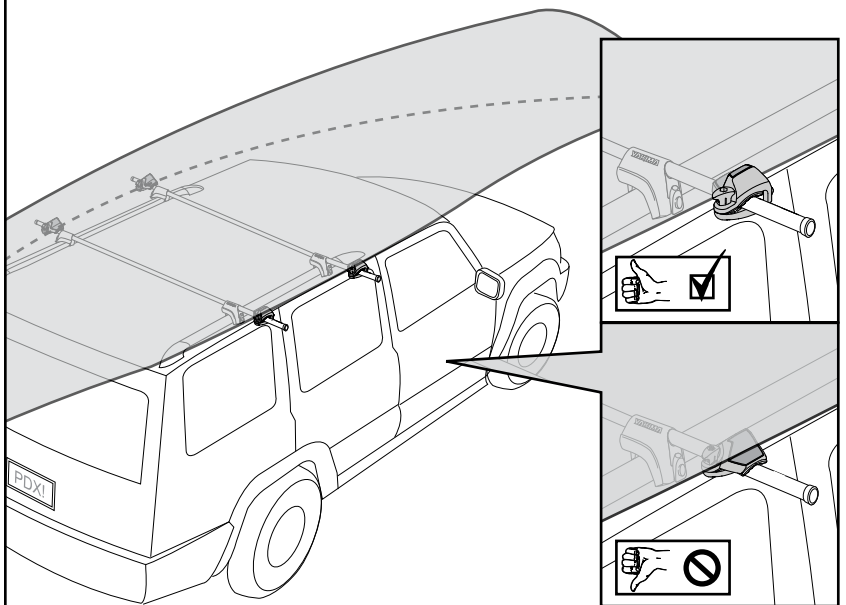

5

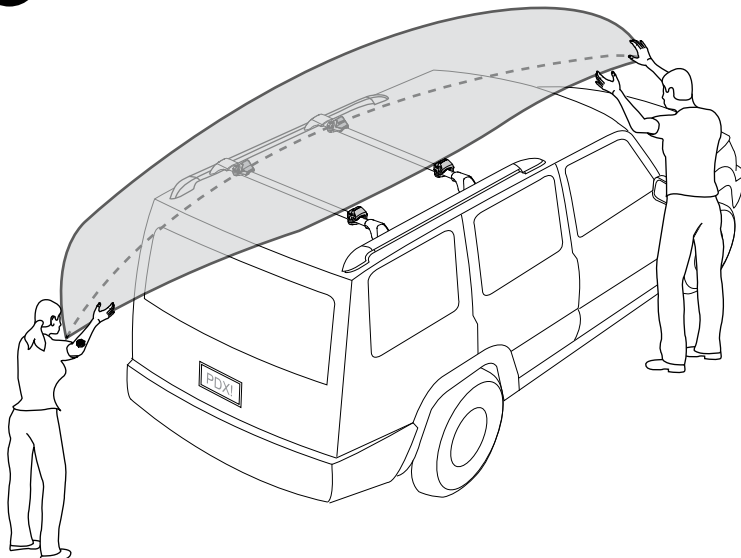

sold separately - SHOWBOAT

ShowBoat 66
(Part# 8004068)
Visit Yakima.com
for more details.

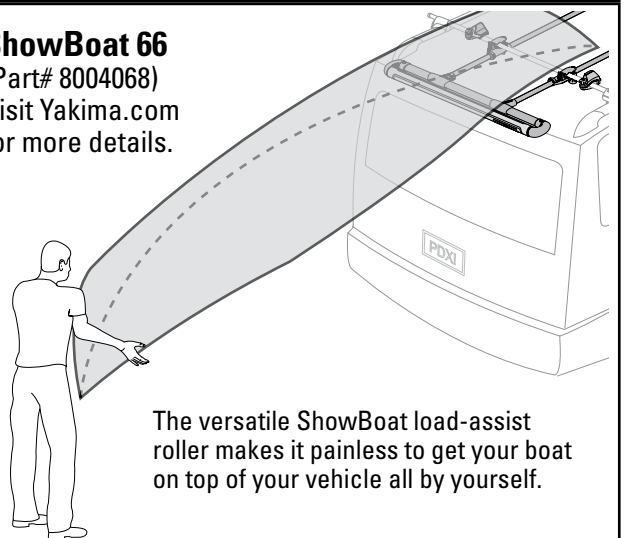

The versatile ShowBoat load-assist roller makes it painless to get your boat on top of your vehicle all by yourself.

6

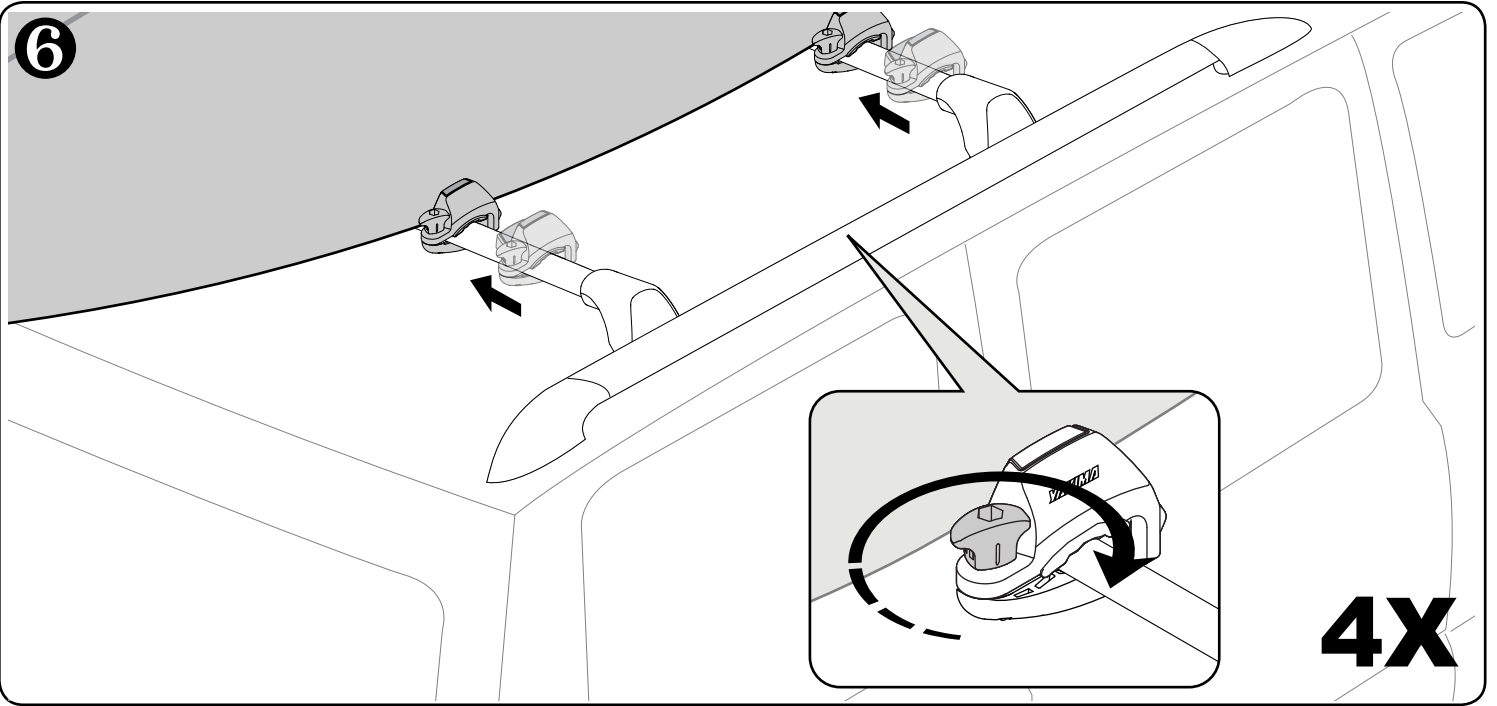

7

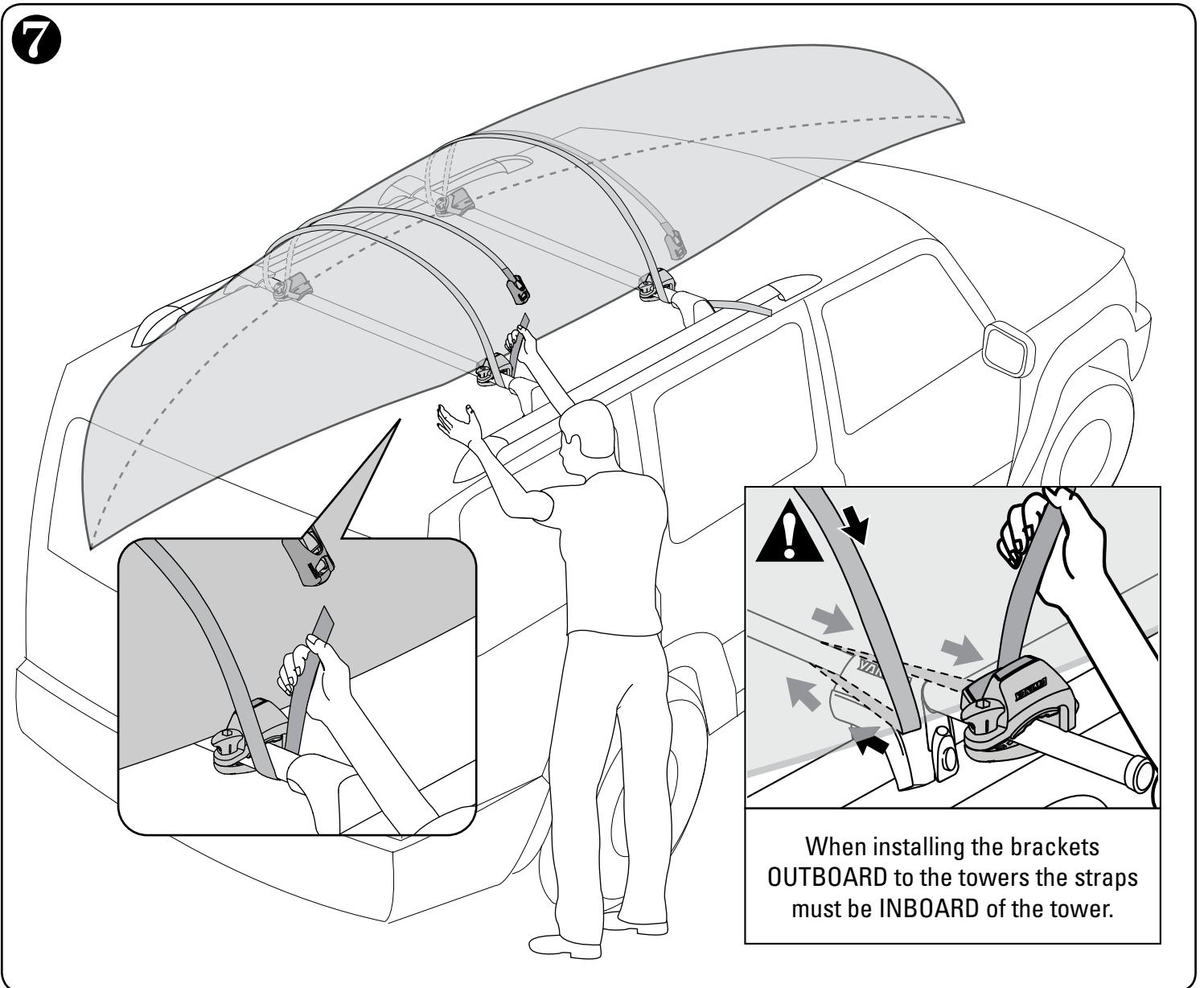

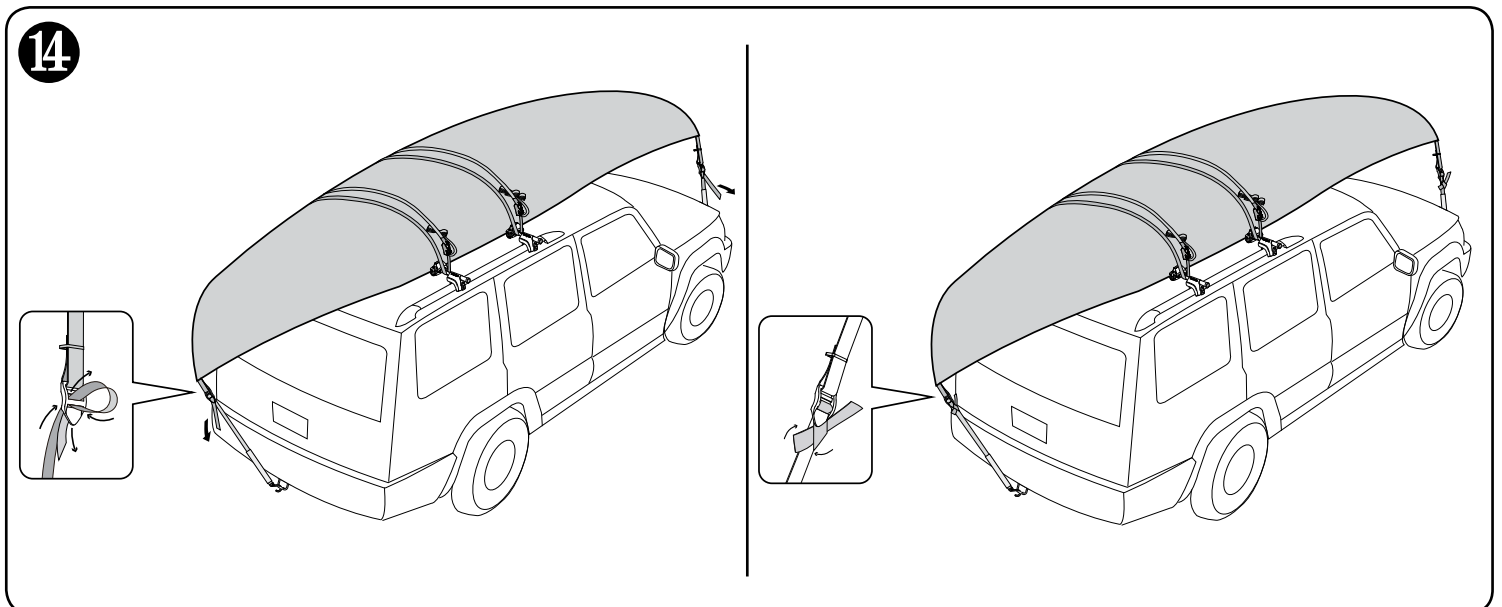
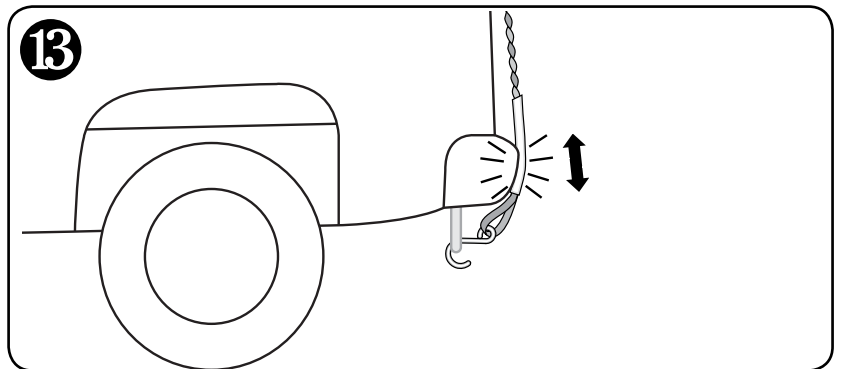
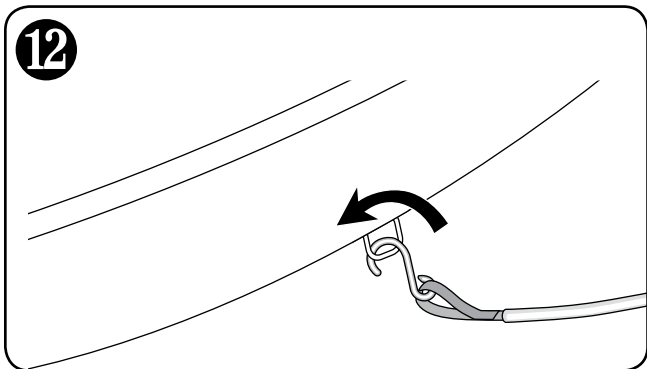
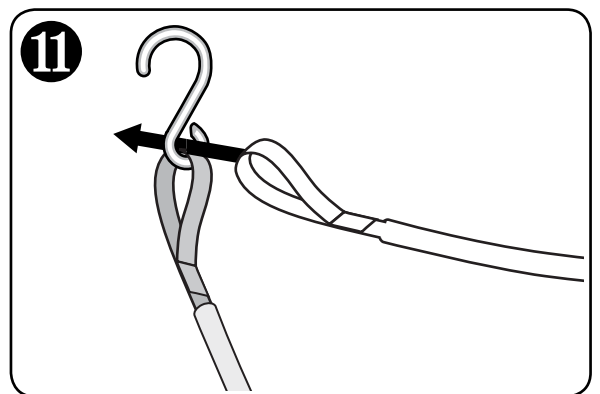
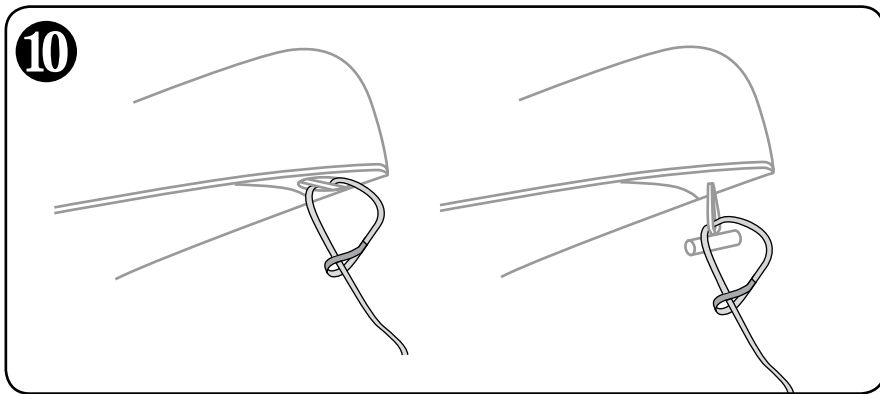
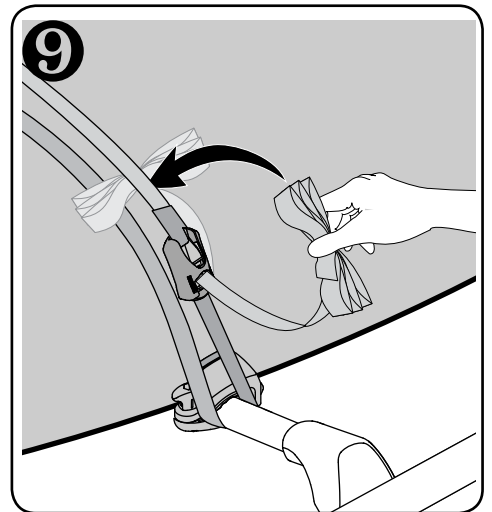
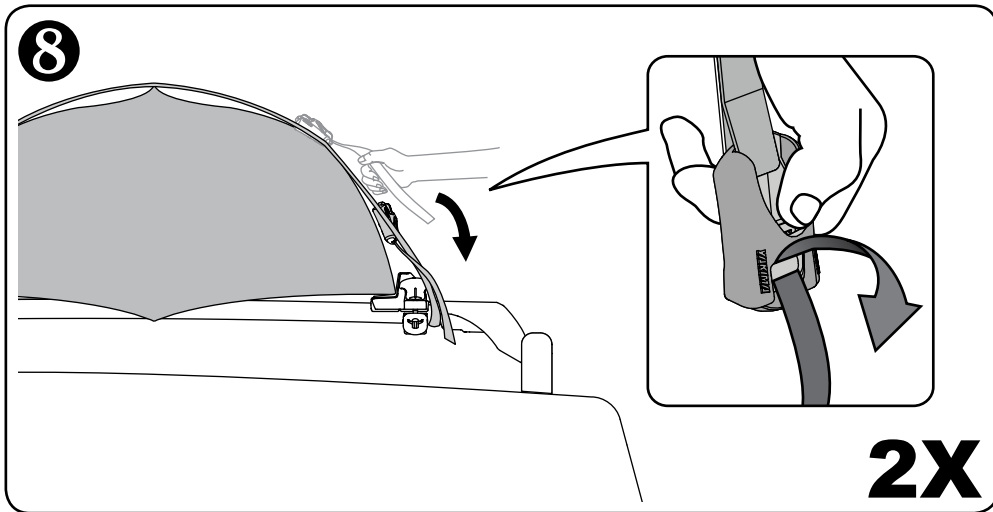

15

TEST BOAT

Test movement by rocking boat.
Tighten knobs and straps if
loose. Do not operate vehicle
unless boat is secure.

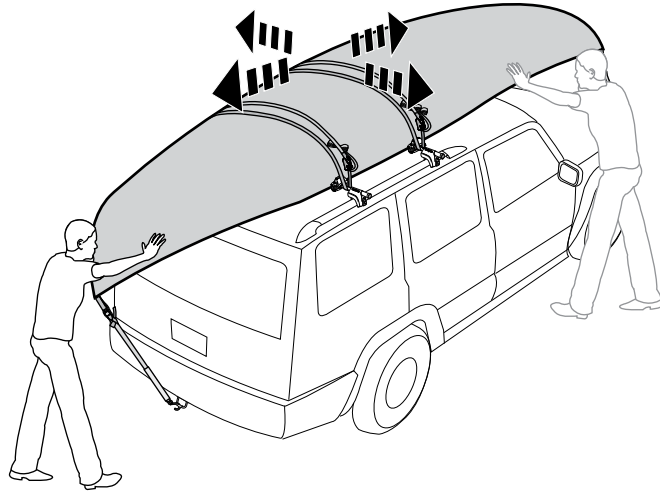

IMPORTANT!

Be sure to read all
the warnings and
warranty information
contained in the
insert accompanying
these instructions!



USE CAUTION



- Always follow posted speed limits and highway warnings.
- Adjust speed and driving based on road conditions (heavy winds, gusts, etc).

WEIGHT LIMITS

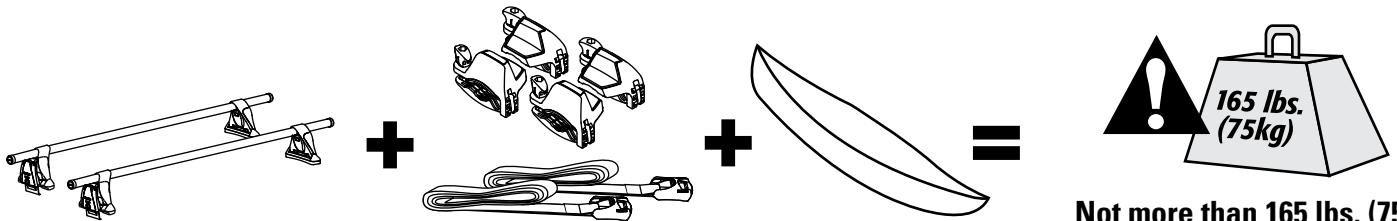

Not more than 165 lbs. (75 kg) or no more than vehicle manufacturer's rating.

USE CAUTION



Failure to secure front and rear of long loads to ends of vehicle can result in property damage, personal injury, or death.

REAR HATCH

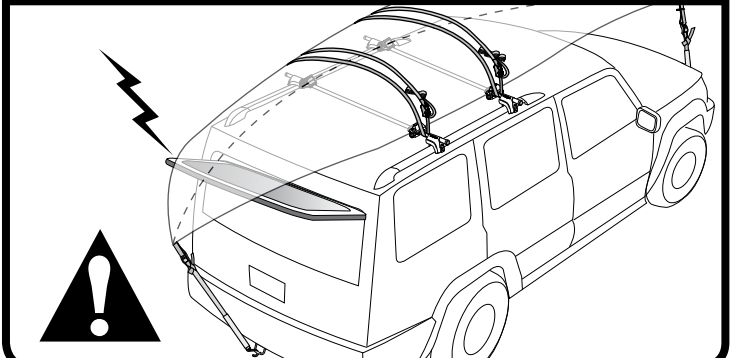

KEEP THESE INSTRUCTIONS!

Déplacer les barres transversales dans la meilleure position de façon à centrer le bateau sur le véhicule tout en respectant le tableau ci-dessous. NE PAS DÉPLACER LES TOURS Q.

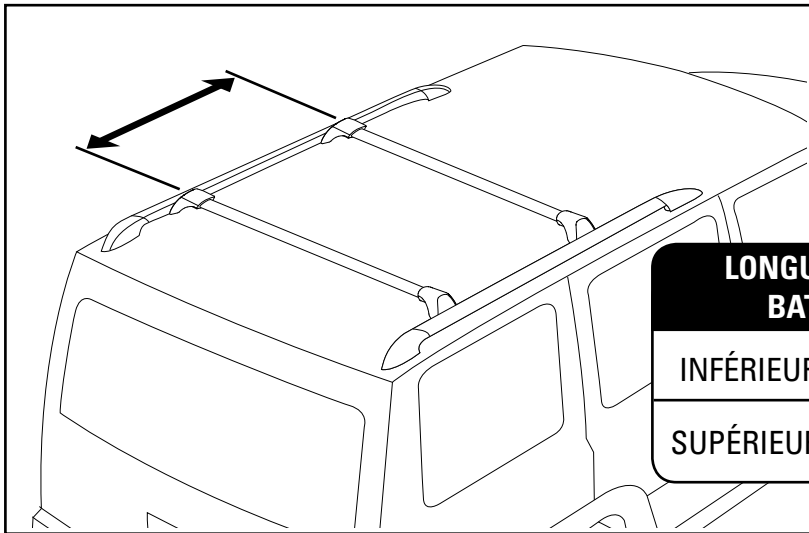

| LONGUEUR DU BATEAU | EXTENSION MINIMALE DE LA BARRE TRANSVERSALE |
|---------------------|---|
| INFÉRIEURE À 426 CM | 64 CM |
| SUPÉRIEURE À 426 CM | 76 CM |

1

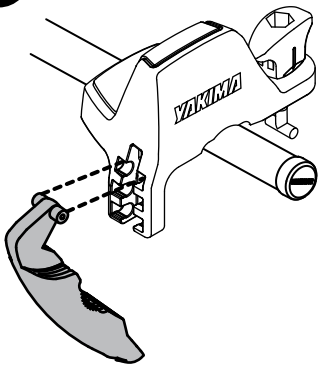

**BARRES ROND
CARRÉES ET WHISPBAR :
ENCOCHE SUPÉRIEURE
ET BOULON EN T
PRÉINSTALLÉ**

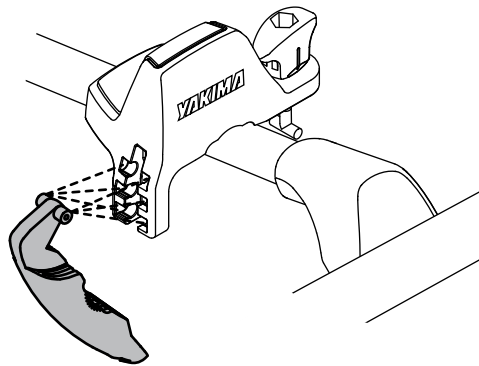

**BARRES TRANSVERSALES
D'ORIGINE : CHOISIR LA
MEILLEURE COMBINAISON
ENCOCHE – BOULON EN T
POUR UNE TENUE SÉCURISÉE**

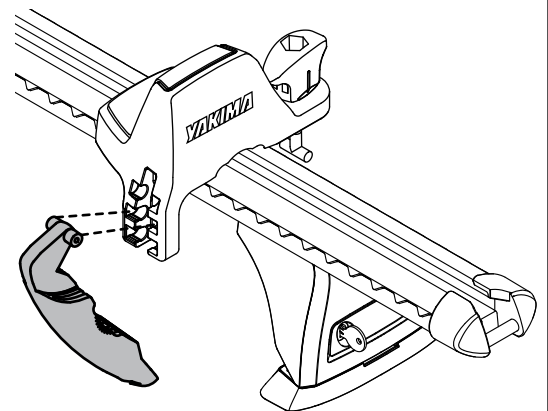

**WHISPBAR HD :
ENCOCHE DU MILIEU ET
BOULON LONG**

2

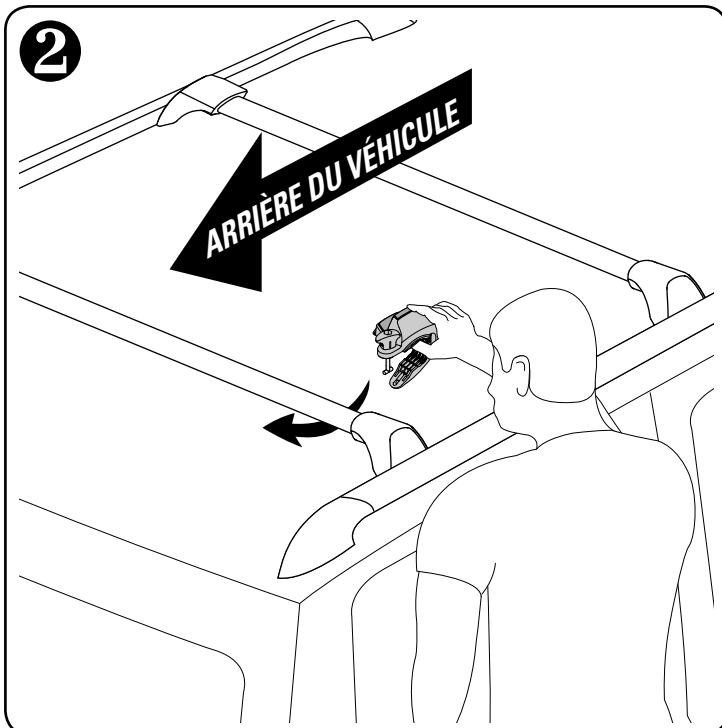

3

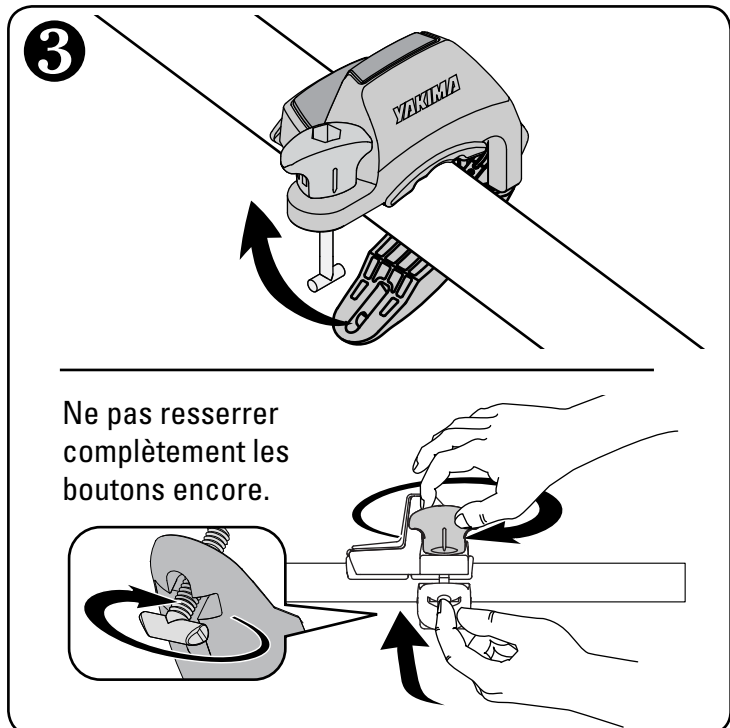

4 Installer les supports à l'extrémité des barres.

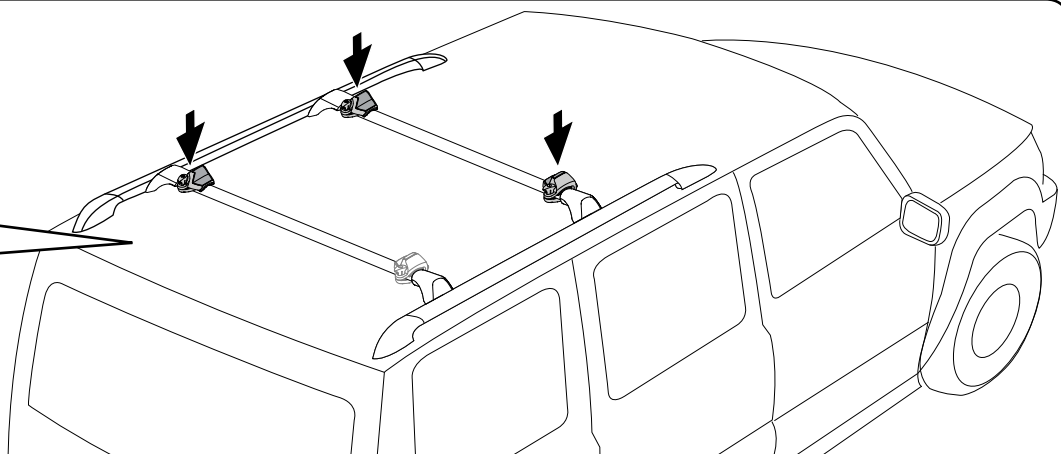
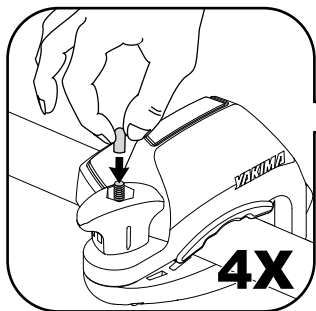

Gros bateau?

Besoin de quelques centimètres (pouces) supplémentaires? Le retournement des supports procure 7,5 cm (3 po) supplémentaires.

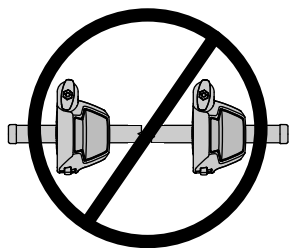
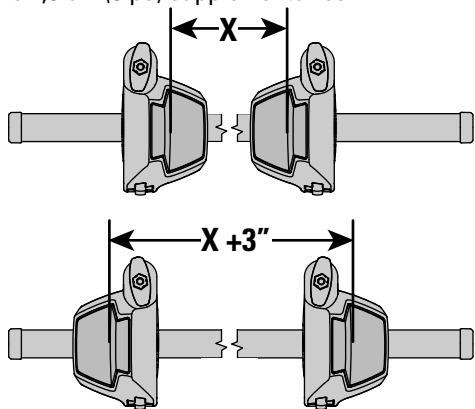

Mélanger l'orientation des supports dans les applications n'est pas acceptable.

Gros bateau?

Besoin de plus que quelques centimètres (pouces) supplémentaires? Un système de base de Yakima permettra d'installer le KeelOver à l'extérieur des tours pour accepter les bateaux plus gros.

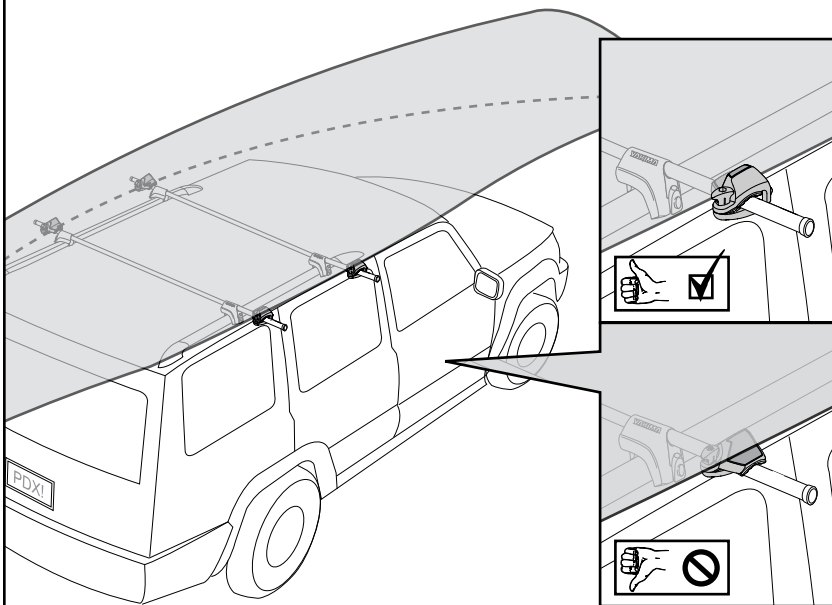

5

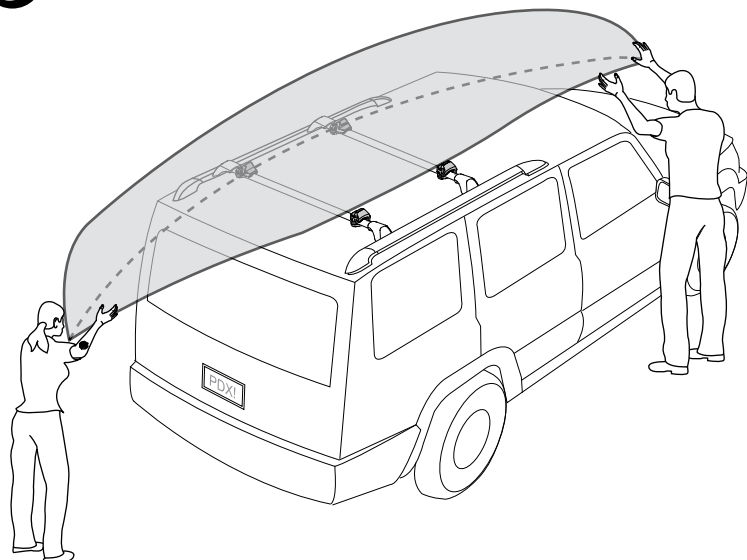

vendu séparément – SHOWBOAT

ShowBoat 66
(N° de pièce 8004068)
Visitez Yakima.com
pour plus de détails.

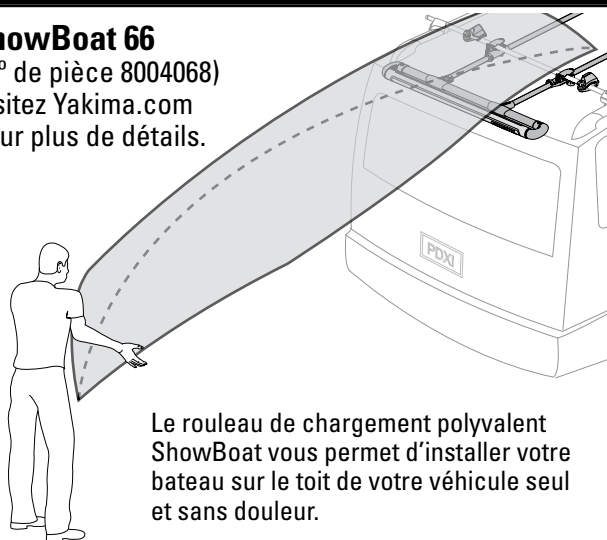

Le rouleau de chargement polyvalent ShowBoat vous permet d'installer votre bateau sur le toit de votre véhicule seul et sans douleur.

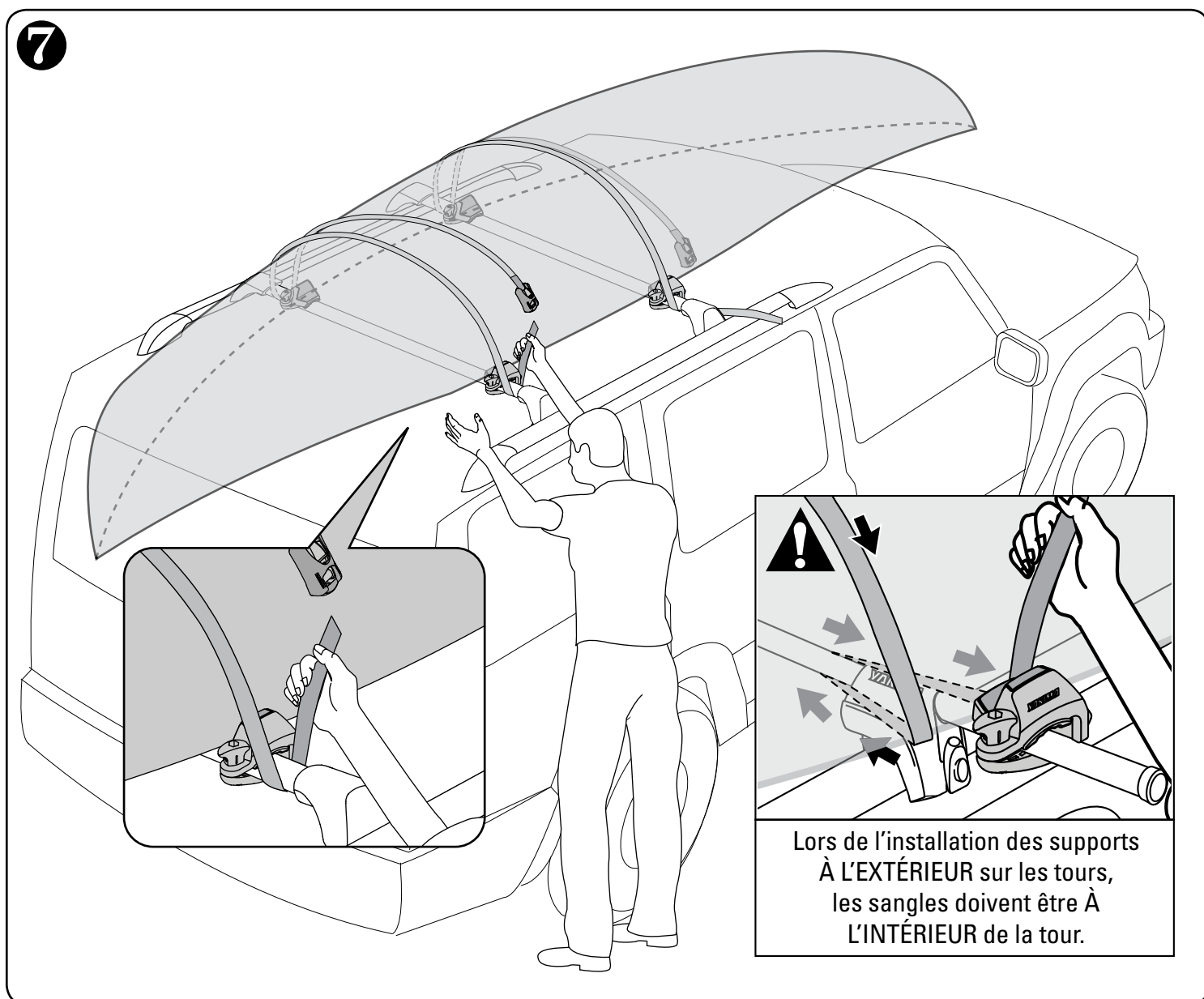
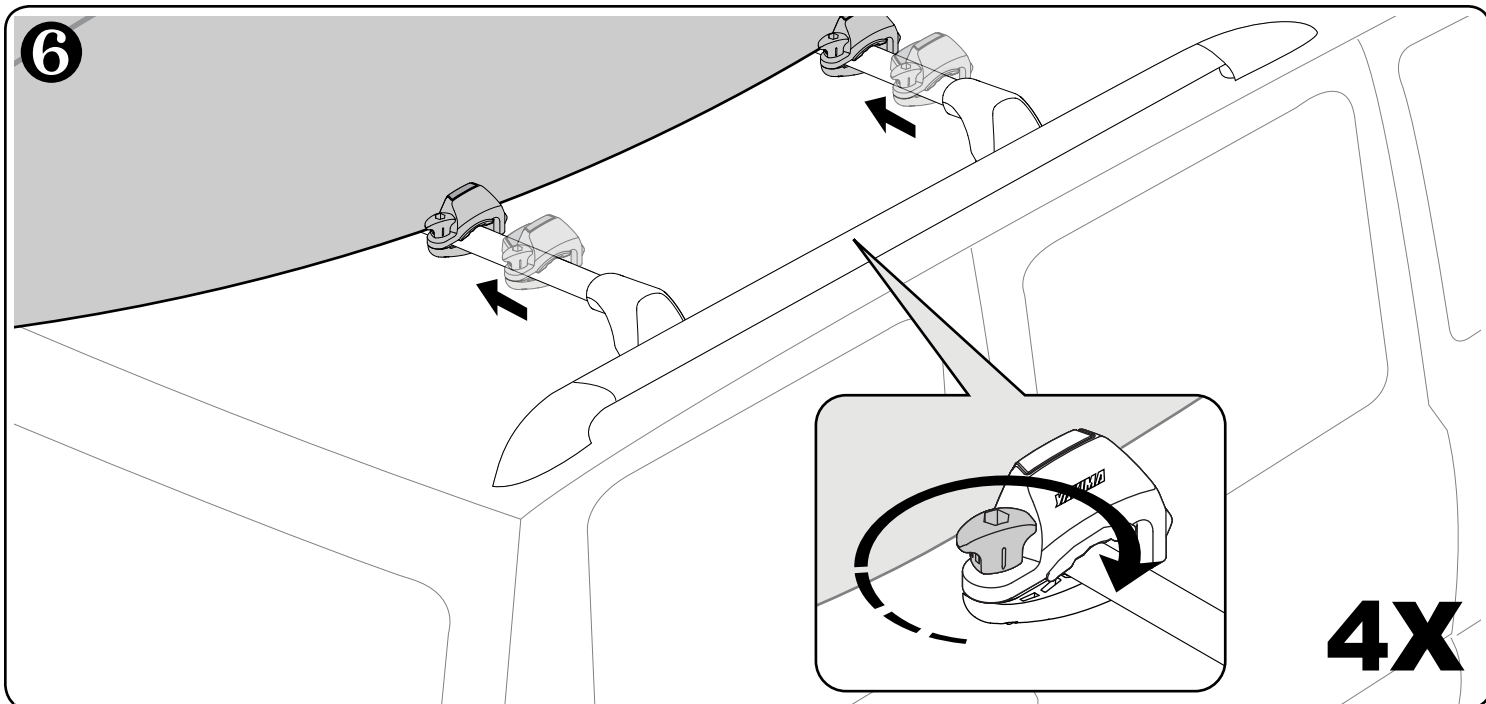

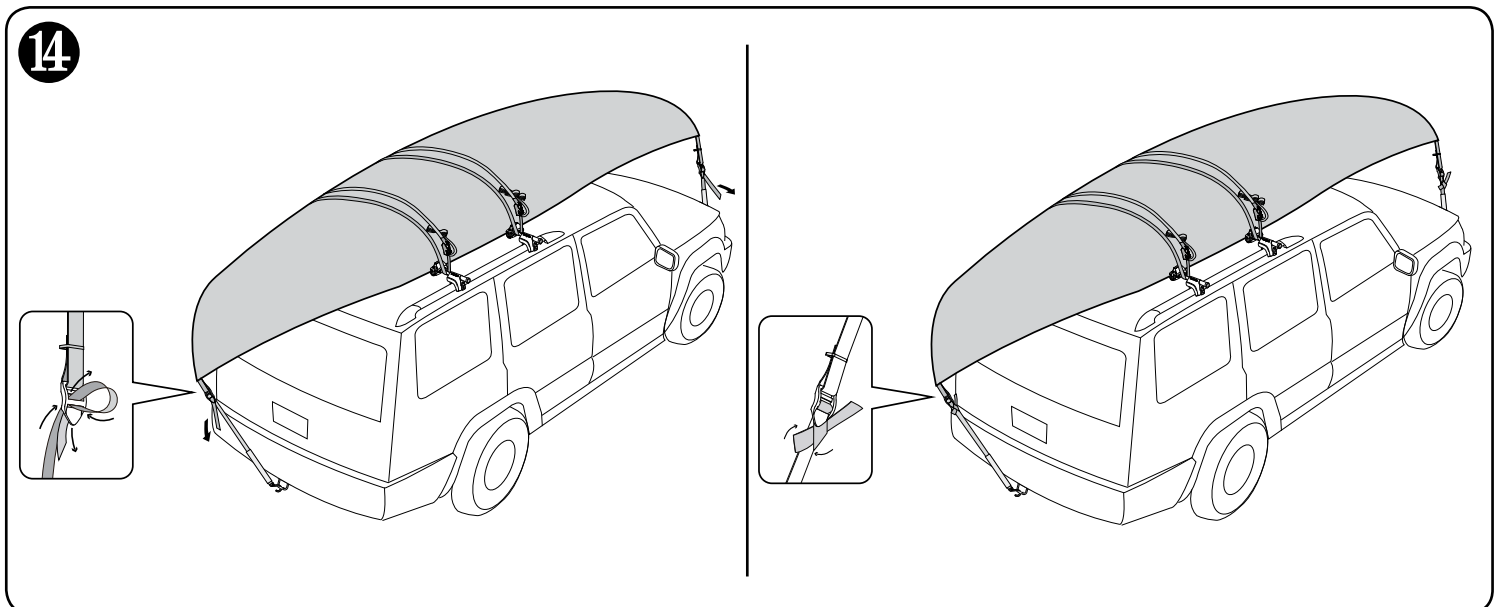
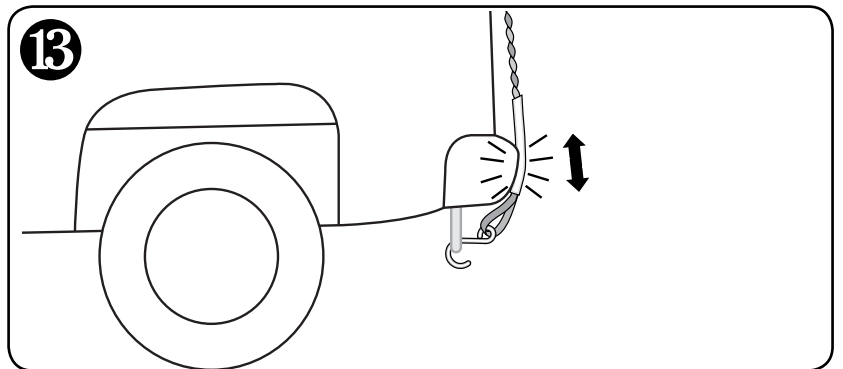
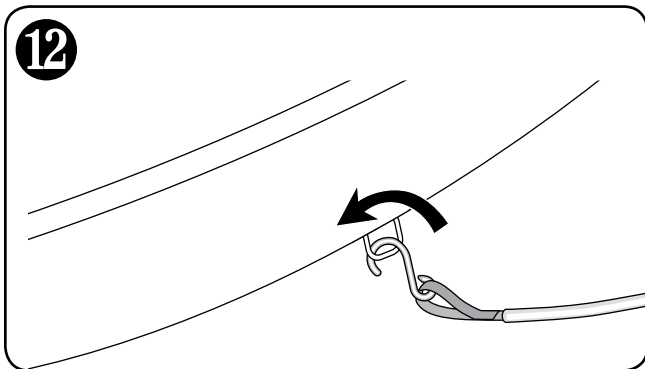
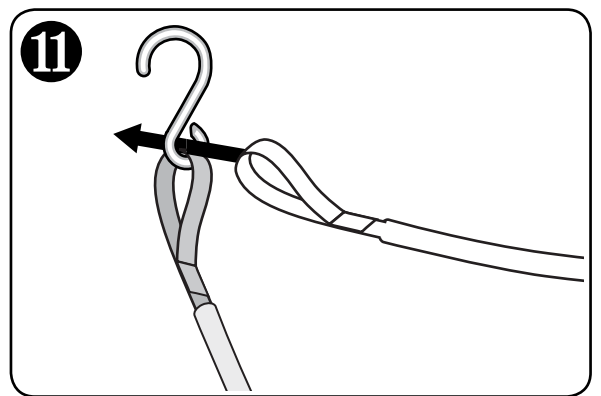
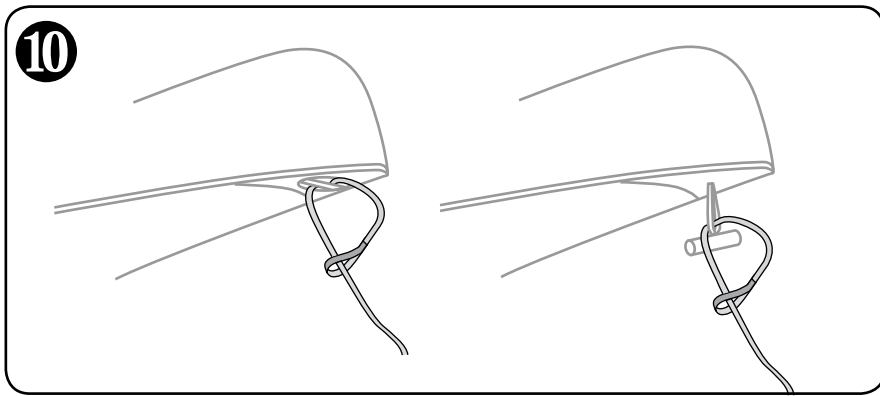
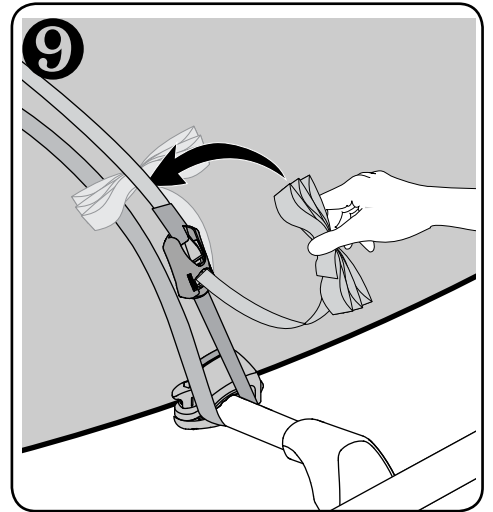
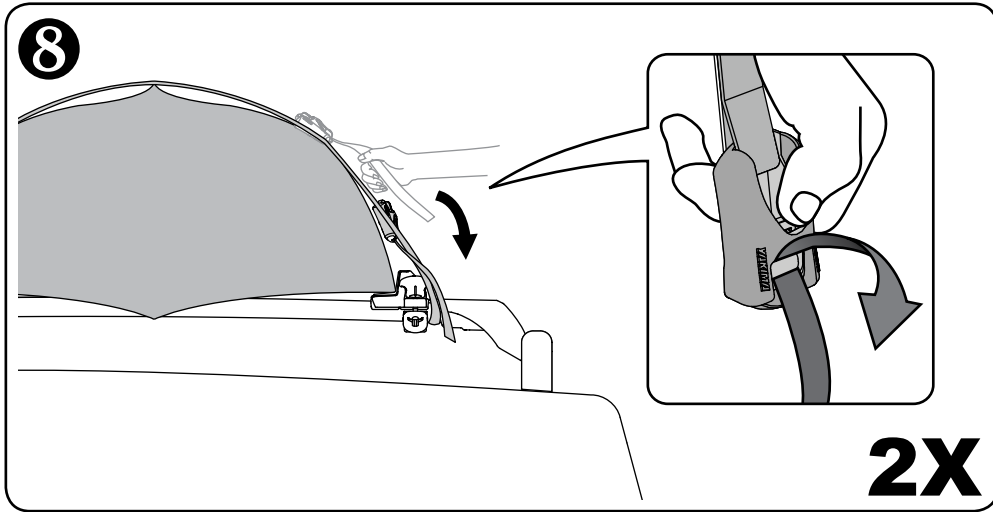

15

ESSAI DU BATEAU

Tester le mouvement en balançant le bateau. Resserrer les boutons et les sangles si c'est lâche. Ne pas conduire le véhicule à moins que le bateau ne soit sécurisé.

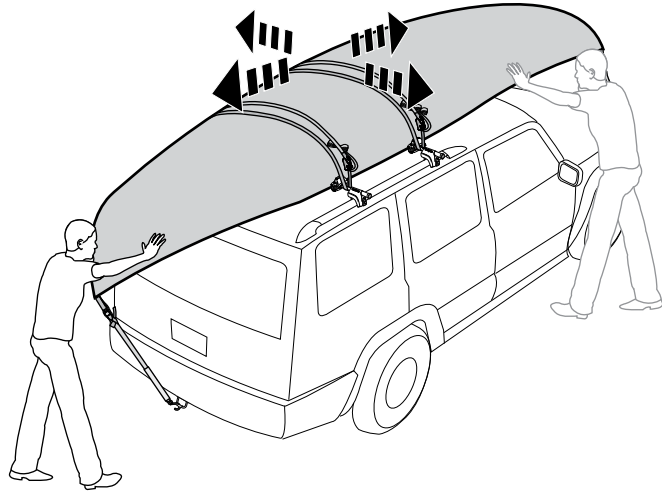

IMPORTANT!

Bien lire tous les avertissements et les renseignements de garantie contenus dans le dépliant qui accompagne ces directives!



FAIRE ATTENTION



- Toujours respecter les limites de vitesse affichées et les avertissements autoroutiers.
- Ajuster la vitesse et la conduite en fonction des conditions routières (vents violents, rafales, etc.).

LIMITES DE POIDS

SUPPORT DE BASE (SI PROVENANT DE MARCHÉ SECONDAIRE) + CE PRODUIT (2.6 lbs. / 1.2 kg) + CHARGE (CHARGE MAXIMALE : 54,4 KG / 120 LB) = **165 lbs. (75kg)**

Maximum de 75 kg (165 lb) ou sans excéder la valeur nominale du fabricant du véhicule.

FAIRE ATTENTION



L'omission de sécuriser l'avant et l'arrière de charges longues aux extrémités du véhicule peut engendrer des dommages à celui-ci, des lésions corporelles ou la mort.

HAYON

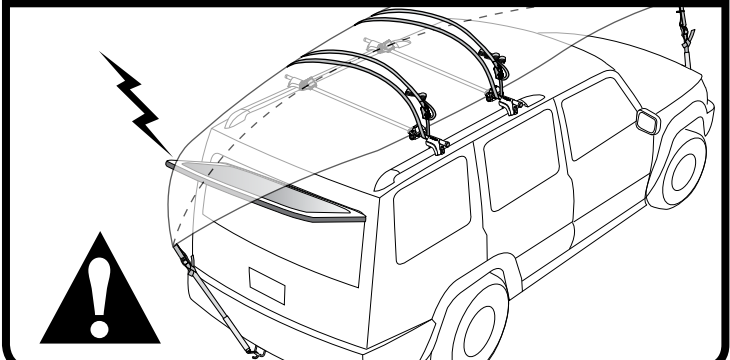

CONSERVER CES DIRECTIVES!

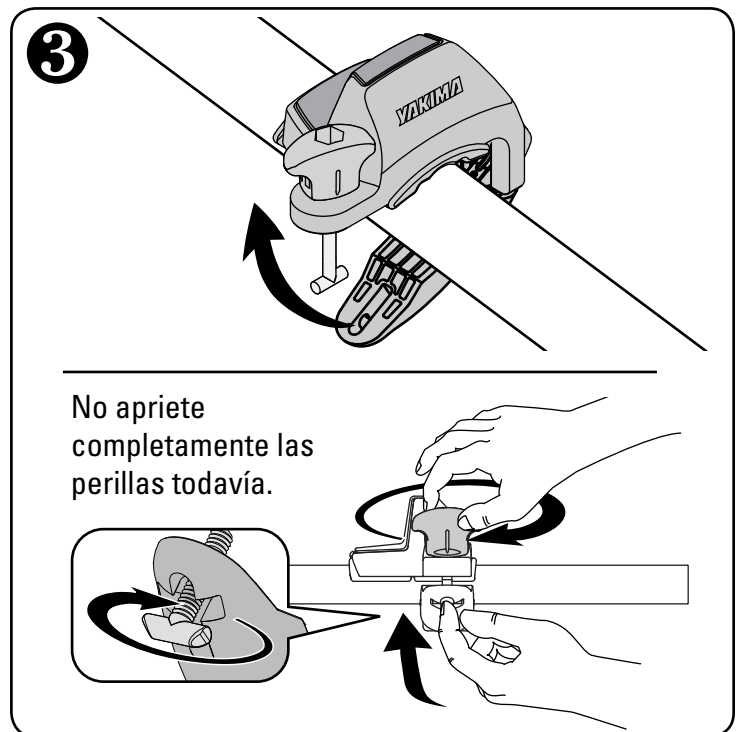
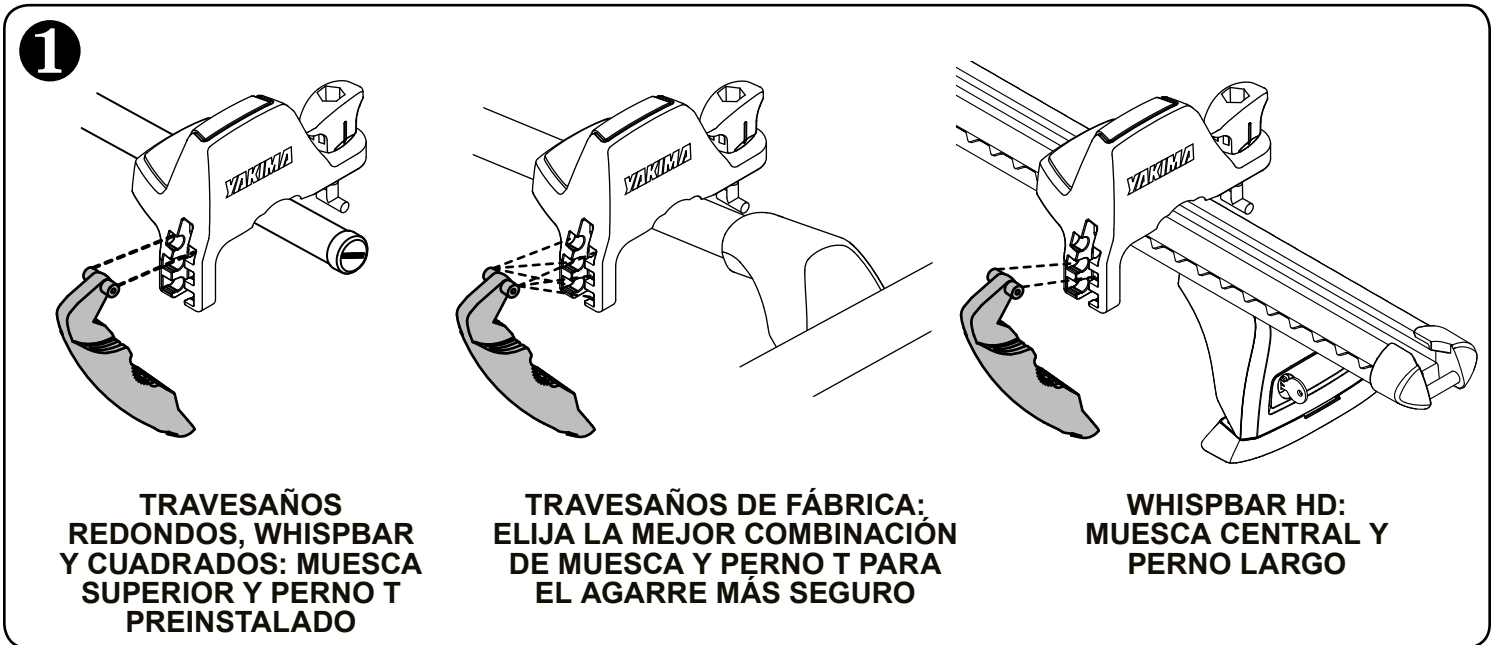
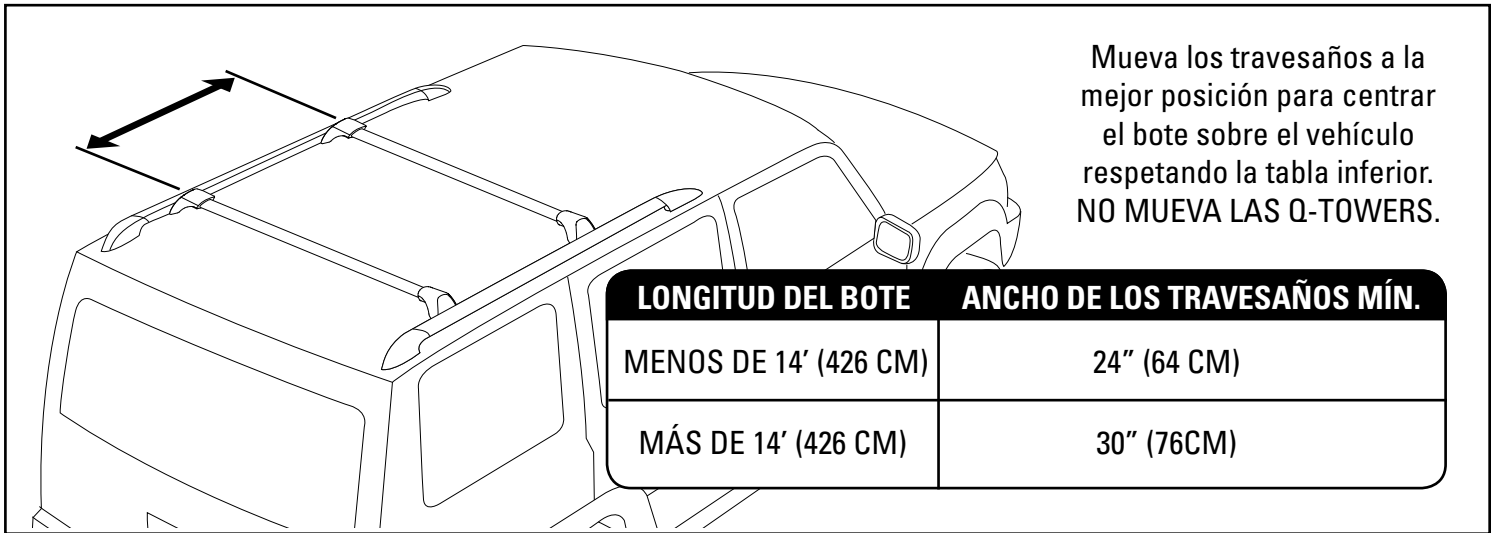

4

Instale las abrazaderas en los extremos de los travesaños.

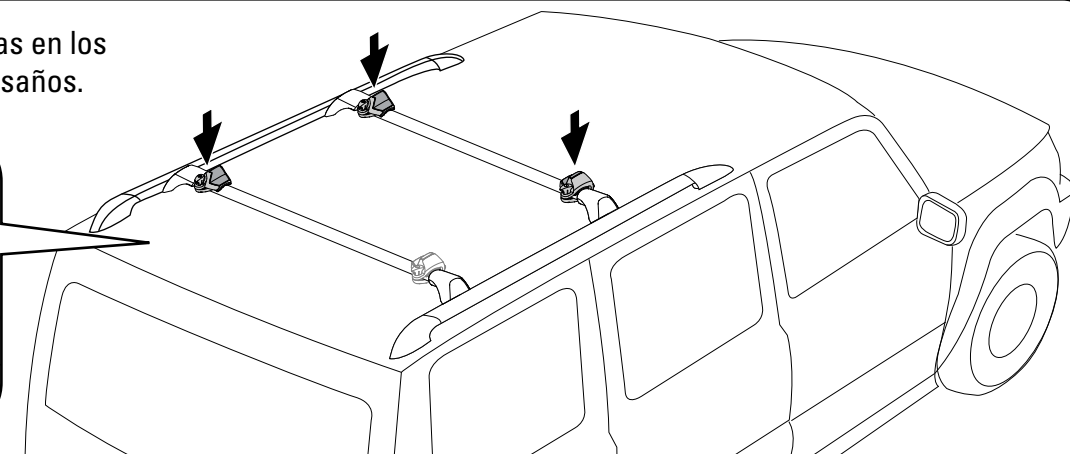
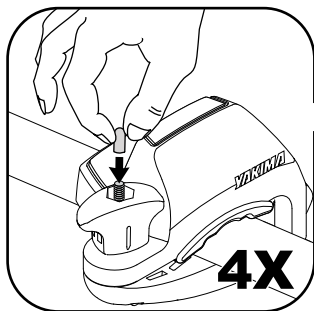

¿Bote GRANDE?

¿Necesita algunas pulgadas más? Al voltear las abrazaderas, puede obtener hasta 3 pulgadas (7.6 cm) adicionales.

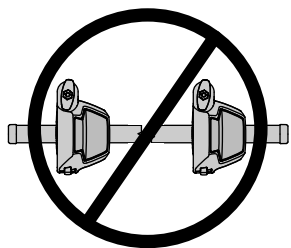
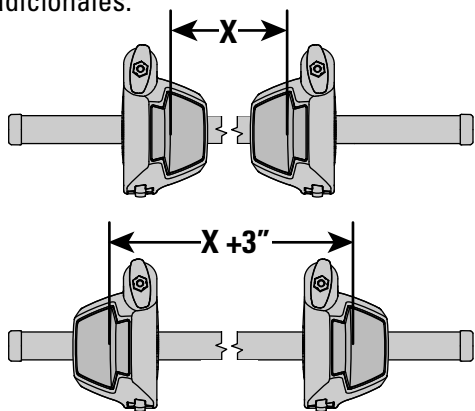

No se permite combinar la dirección de las abrazaderas.

¿Bote GRANDE?

¿Necesita más que unas cuantas pulgadas? Un sistema de base Yakima permitirá que el KeelOver se instale fuera de las torres para acomodar botes más grandes.

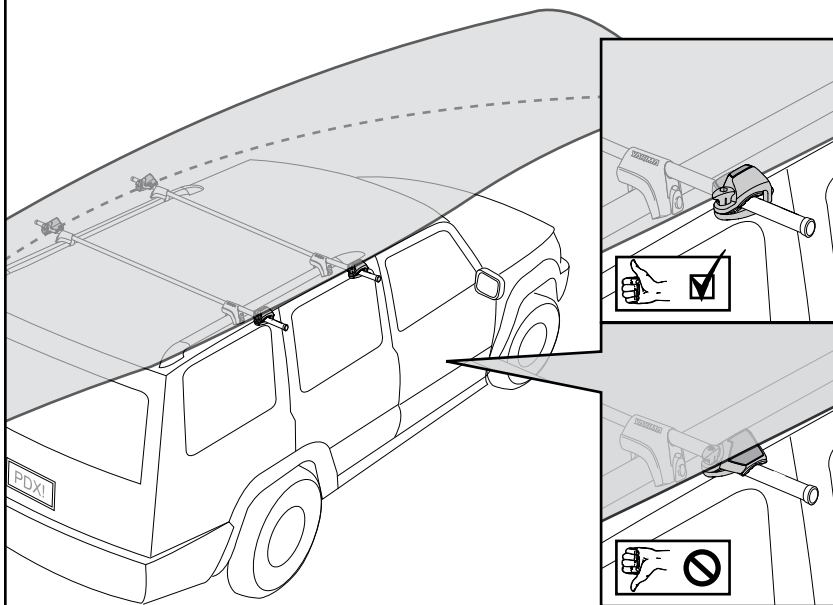
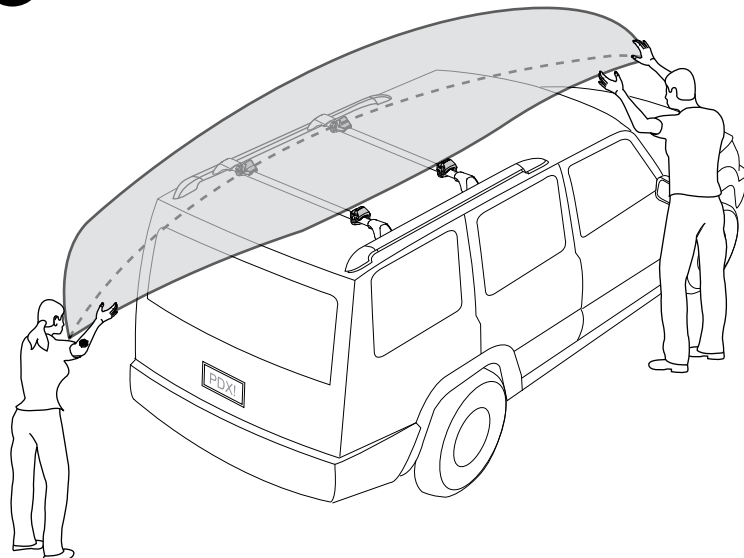
**5**

se vende por separado – **SHOWBOAT**

ShowBoat 66
(Parte n.º 8004068)
Visite Yakima.com
para obtener más
detalles.

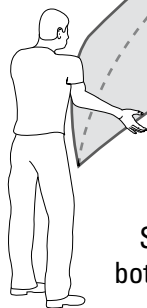

El versátil rodillo de carga asistida ShowBoat permite que usted suba el bote a su vehículo sin ayuda ni dificultad.

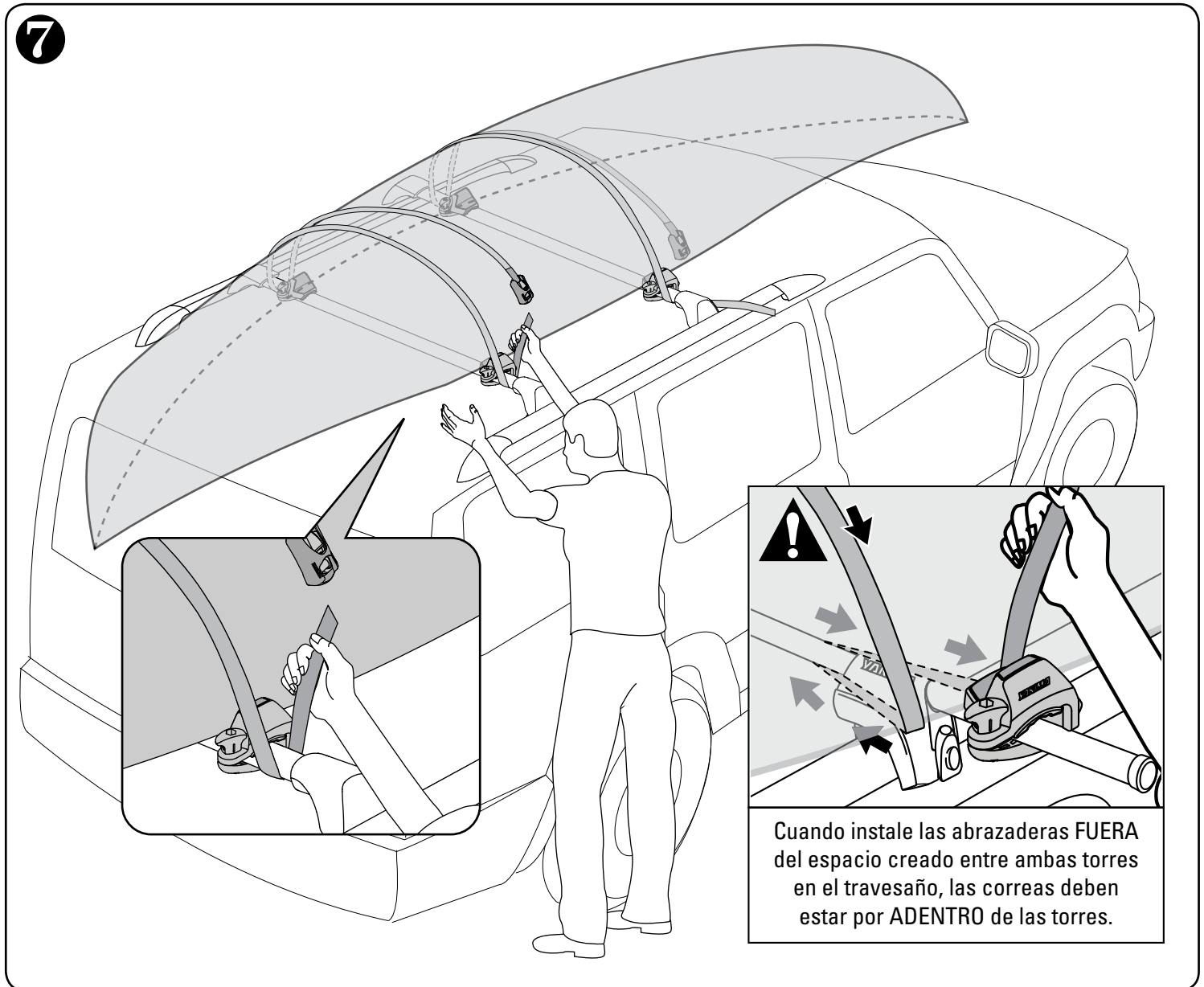
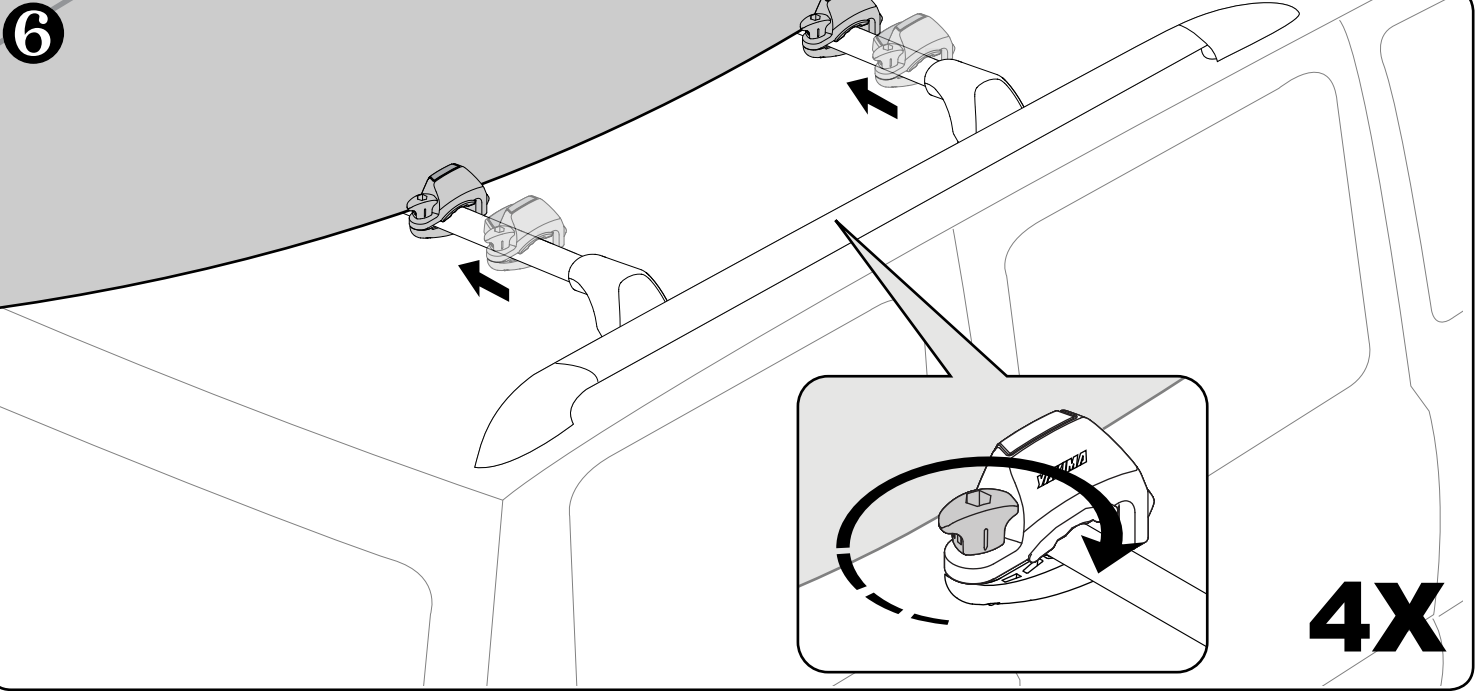

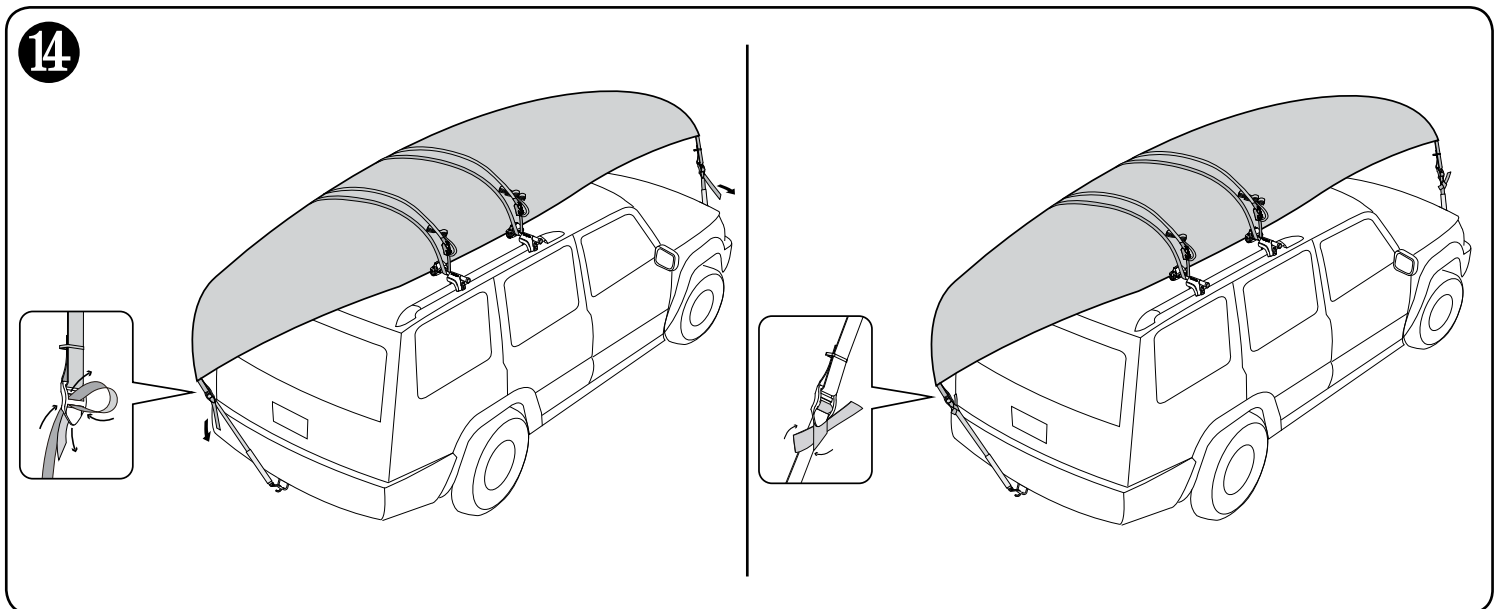
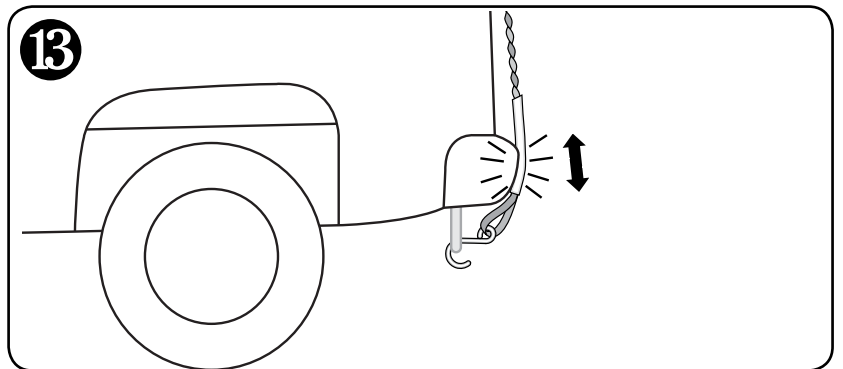
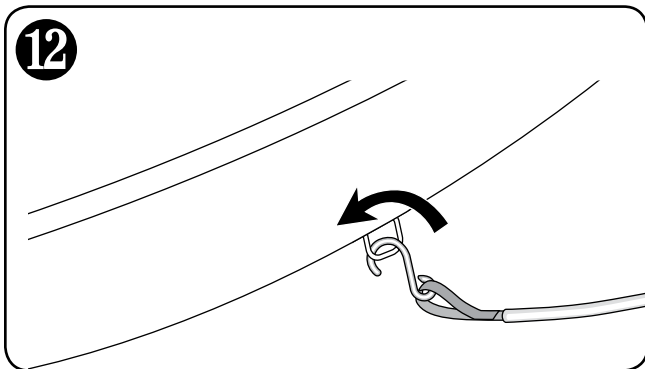
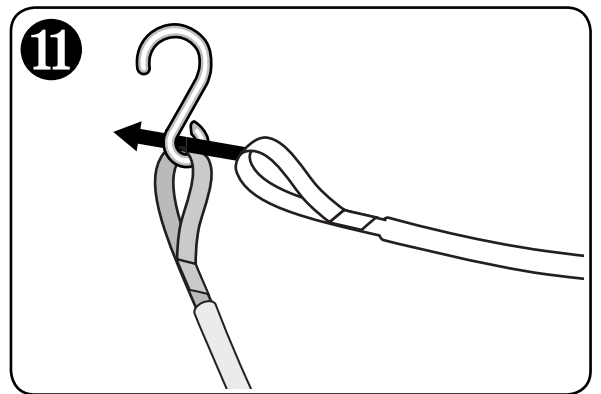
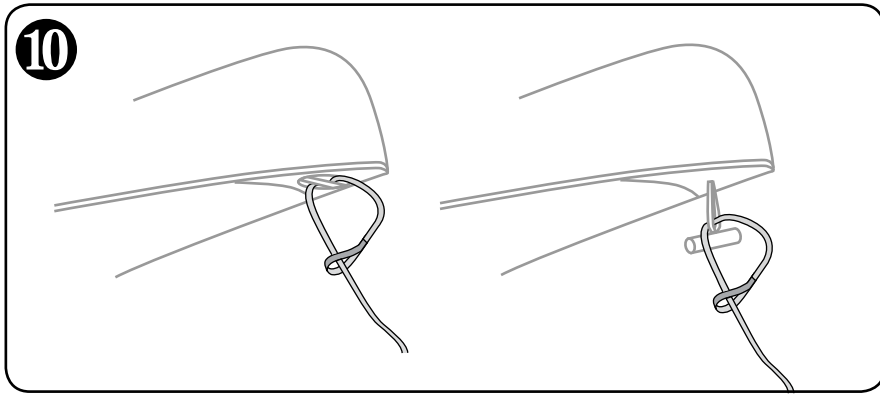
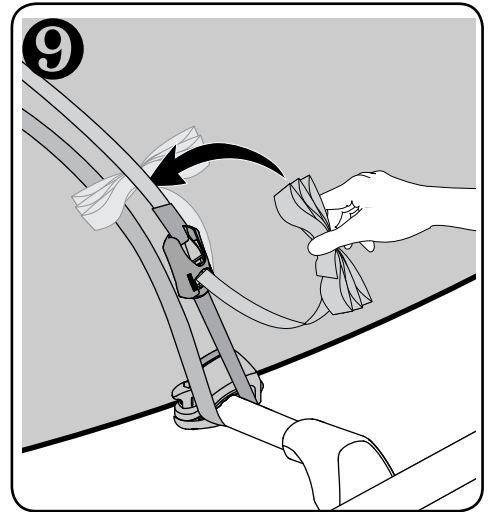
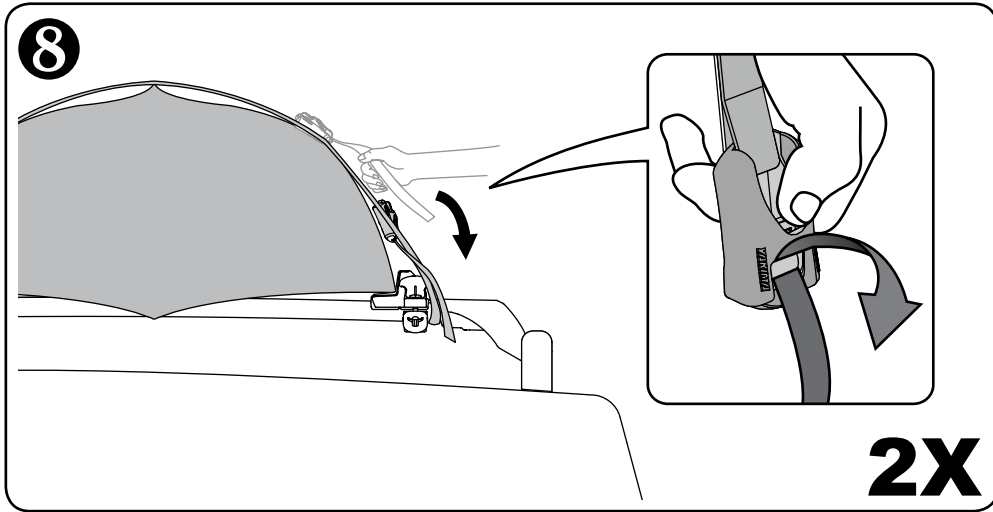

15

COMPRUEBE LA ESTABILIDAD DEL BOTE

Mueva el bote para comprobar la estabilidad de éste. Apriete las perillas y las correas en caso de estar sueltas. No opere el vehículo hasta que el bote esté seguro.

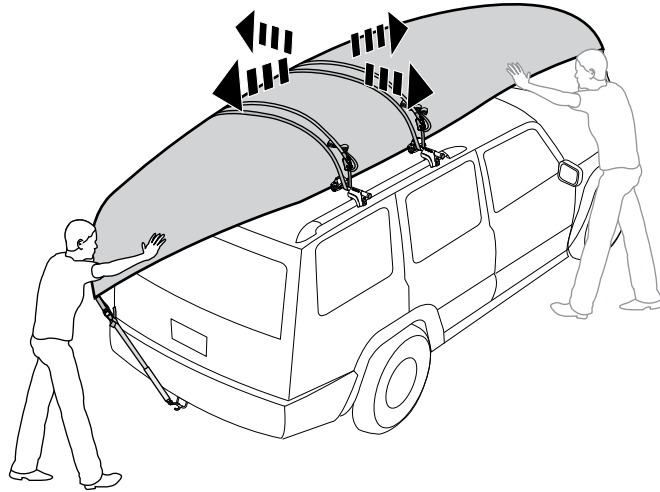

¡IMPORTANTE!

Asegúrese de leer toda la información sobre advertencias y garantía contenida en el anexo de estas instrucciones.



TENGA CUIDADO



- Siempre respete los señalamientos del límite de velocidad y de advertencia en carretera.
- Ajuste la velocidad y su manera de conducir según las condiciones del camino (vientos fuertes, ráfagas, etc.).

LÍMITES DE PESO

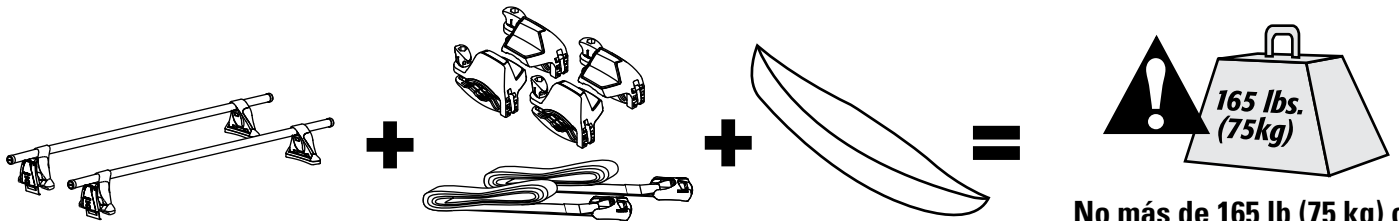

PARRILLA DE BASE (POSTVENTA)

ESTE PRODUCTO (2.6 lbs. / 1.2 kg)

CARGA (CARGA MÁXIMA: 120 LB / 54.4 KG)

No más de 165 lb (75 kg) o no más que el índice del fabricante del vehículo.

TENGA CUIDADO



Si no se aseguran el frente y la parte posterior de las cargas largas a los extremos del vehículo, la consecuencia podría ser daños materiales, lesiones corporales o fallecimiento.

PORTEZUELA TRASERA

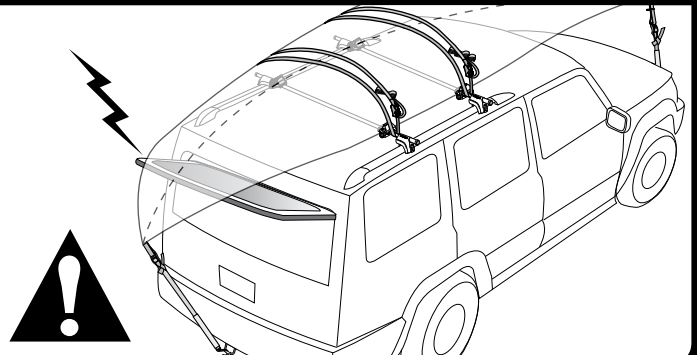

GUARDE ESTAS INSTRUCCIONES