

K403 ASSEMBLY AND FITTING INSTRUCTIONS

Kit Contains

- | | |
|------------------------------------|-----------------------------------------------------------------------------------------------------|
| 1 x Instructions | Remove parts from box & check
Contact your Prorack dealer if any
parts are missing or damaged |
| 2 x Front Clamps (Part number 542) | |
| 2 x Rear Clamps (Part number 543) | |
| 4 x Stepped Rubber Pads | |

Maximum
Whispbar
Load
Rating

40
kg

When Fitted and loaded
correctly

Items you will require that are not included:

Tape measure

Important Note:

Whispbar Flush Bar pictured in these instructions, also applicable for Whispbar Through Bar

1. Crossbar Preparation

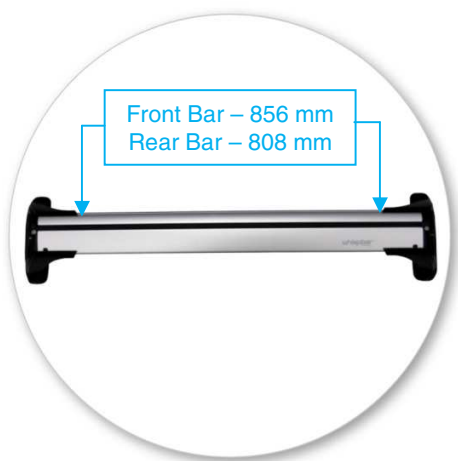

1.1

- Set the bars to length (refer to the crossbar instructions for adjustment description)



1.2

- Fit stepped rubber pad (from fitting kit) to foot
- Press pad firmly onto foot by putting thumb pressure on area where pad spigots engage
- The pad shape may vary from the photo.

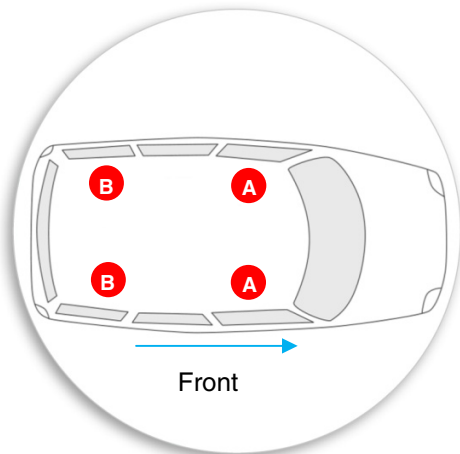

1.3

- Letters refer to the clamp part numbers
- Part numbers are stamped on clamps
- (A) Refers to Clamp 542
- (B) Refers to Clamp 543

2. Positioning Crossbar on Vehicle



2.1

- Locate the bars on the vehicle as indicated on the photo
- Remove clamp screws
- Fit clamps
- Clamps directly to edge of roof under the doors
- Replace clamp screws
- Progressively tighten the screws. Alternate from side to side to tension evenly.



2.2

- Check that crossbar feels tight on the roof
- Refit covers to leg.

Warning Notes:

- Use these instruction in conjunction with crossbar instructions

WARNING: Check the Tightness of Screws Regularly