

**GB** Fitting Instructions for Basic Carrier

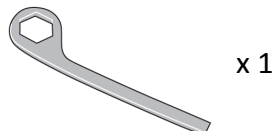

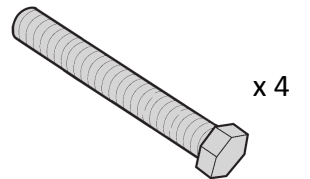

## MAX kgs (lbs)

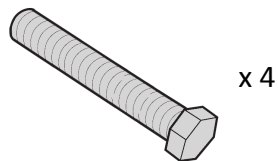
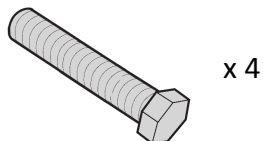
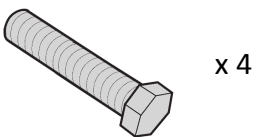
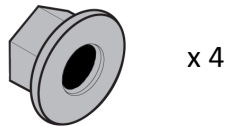
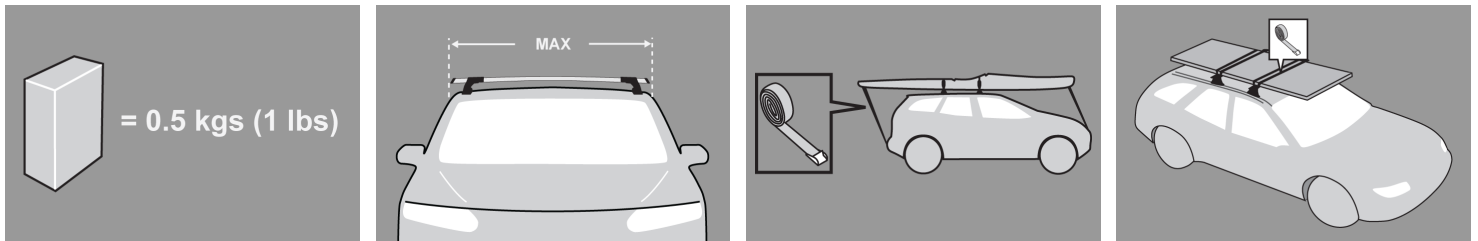

W/P

WHD

### Holden

Combo XC, 5dr Van 01-+  
Combo XC, 5dr Van 01-+

NZ	75 kgs (165 lbs)	100 kgs (220 lbs)
AU	75 kgs (165 lbs)	100 kgs (220 lbs)

### Opel

Combo , 5dr Van 01- 11  
Combo C, 5dr Van 01- 11

ZA	75 kgs (165 lbs)	100 kgs (220 lbs)
EU	75 kgs (165 lbs)	100 kgs (220 lbs)

### Vauxhall

Combo C, 5dr Van 01- 11

EU	75 kgs (165 lbs)	100 kgs (220 lbs)
----	------------------	-------------------

## First Time Installation



- Remove parts from inside the package and check. Contact your dealer if any parts are missing or damaged.

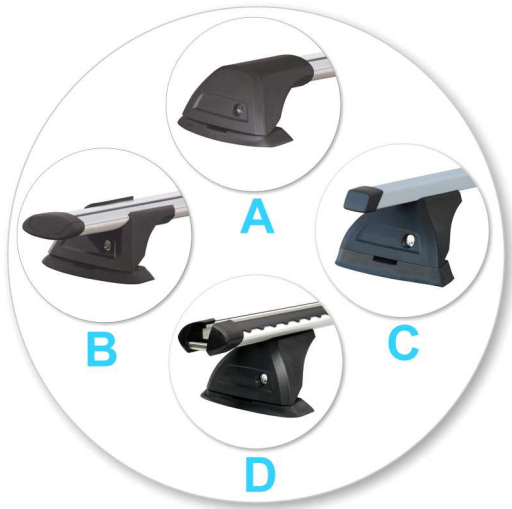

- This kit fits type A, B, C and D.
- These instructions show type A crossbar fitted. They also apply to type B, C and D.



- Use keys to remove covers.



- Use hex screwdriver to reverse adjusting screw 10 turns.



- Press adjusting screw and pull crossbar legs out. Refer to the crossbar instructions for crossbar adjustment.
- Ensure each end of the crossbar is adjusted equally.

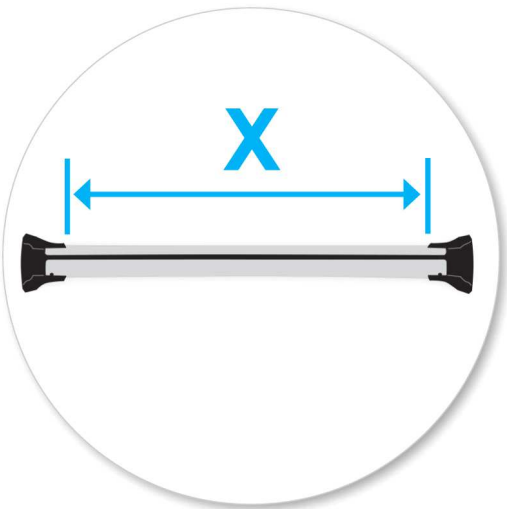

- Set bars to length (refer to the crossbar instructions for crossbar adjustment).
- Please check the rear of this manual for information relating specifically to your vehicle.



- Tighten adjusting screw to 5 Nm (3.7 ft lb).

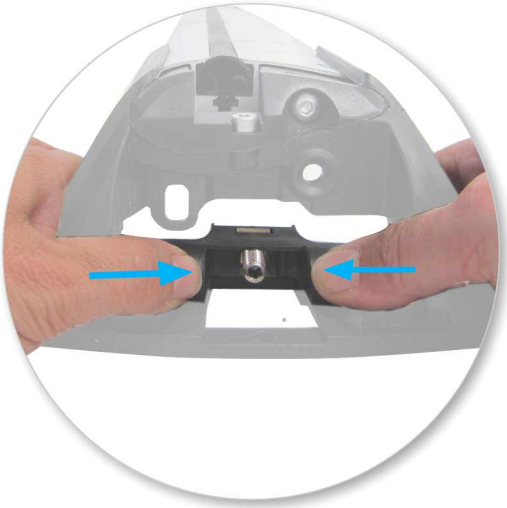

- Remove plastic clamp block by gripping bar leg with fingers and push firmly with thumbs until clamp block drops out behind leg.



- Select plastic internal block (from fitting kit) and insert into foot.
- Repeat for all legs.



- Fit rubber pad (supplied with crossbar) to foot.
- Make sure the pad fits into the holes underneath the foot.

## Fitment



- Remove rear screw only at each fixed-point position.

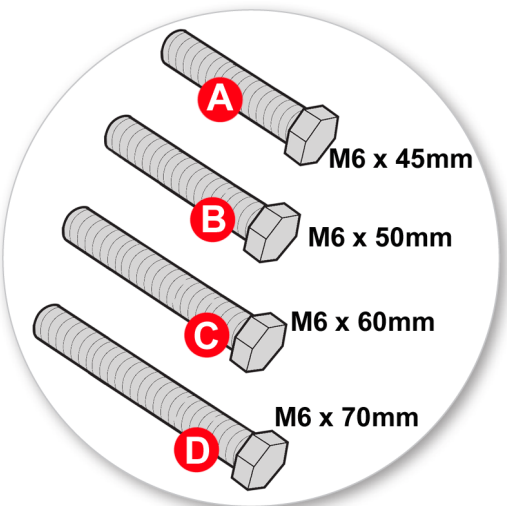

- Sort hex bolts into lengths. Choose correct length for your vehicle.
- A = Not applicable unless advised
- B = Combo Van
- C = Not applicable unless advised
- D = Not applicable unless advised

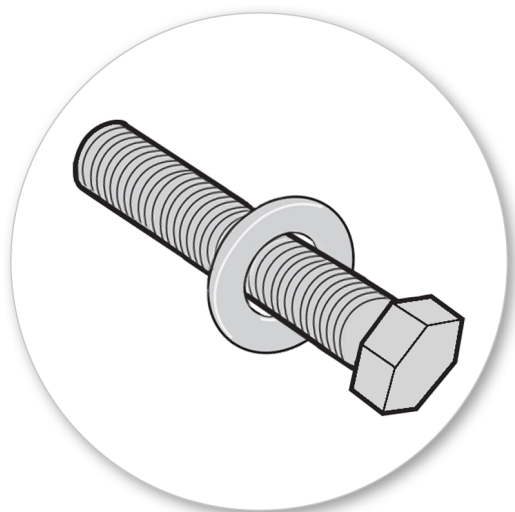

- Place flat washer onto 50mm bolt.



- Install bolt with washer up through the fixed-point from inside vehicle.  
NOTE: May require holding in place by a second person or sticky tape.

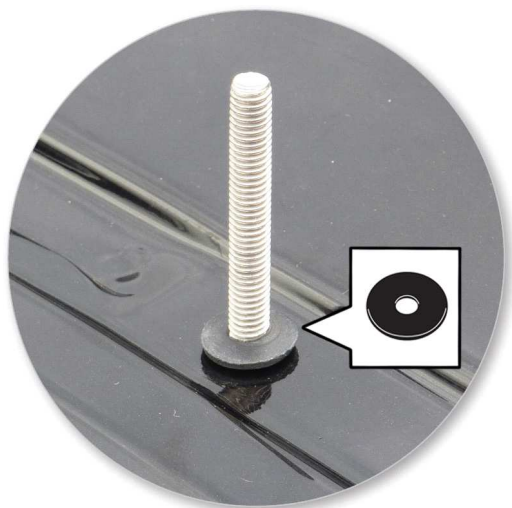

- Place rubber seal over bolt thread as shown.



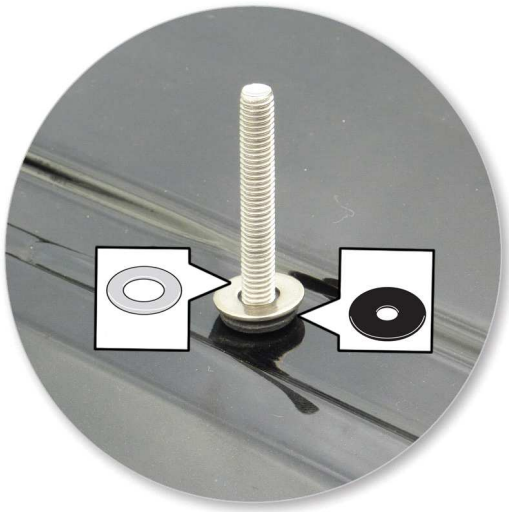

- Place second flat washer over rubber seal.

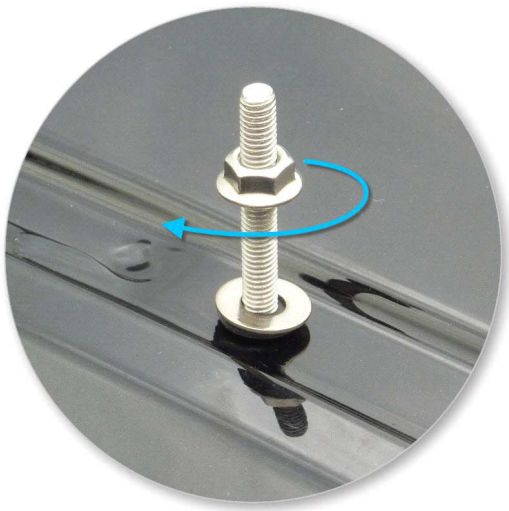

- Screw flange nut onto hex bolt.

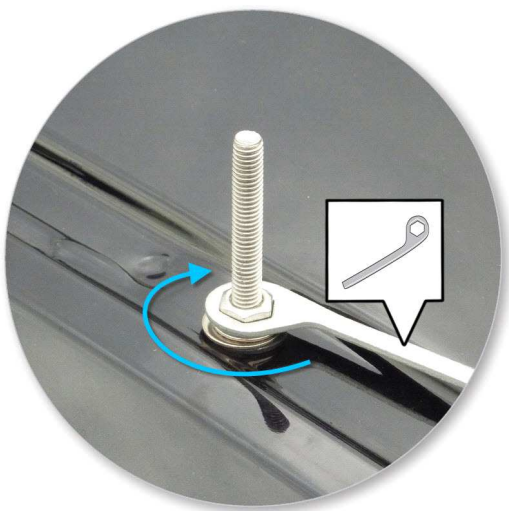

- Tighten flange nut using 10mm (3/8") spanner provided.
- Do not over tighten.





- Check seal is secure.  
NOTE: If seal has slid out from under washer, loosen flange nut slightly.



- Place crossbar foot over grub screws.



- Tighten the red plastic knob. The side with the nut showing should be facing up.



- Ensure the red plastic knob is in the position shown when fully tightened.
- Repeat for all four positions.



- Check crossbar is securely attached to the vehicle.
- Use keys to fit and lock covers

**CAUTION:**  
Recheck all fasteners immediately after a load is applied to the crossbars.  
Regularly check screws are tight.

## Maintenance

- Clean the car roof and surfaces of the product that will be in contact with the car roof.
- Follow the fitting instructions for fitting the product to your vehicle. Make sure all steps are carried out in order.
- Set crossbars a minimum distance of 700mm (27 1/2") apart where no other distance is specified in the fitting instructions. This is especially important when carrying long loads.
- Check unit is securely attached whenever you refit it to the vehicle. If the unit feels loose, refer to the fitting instructions and readjust.
- Some glass/panoramic roofs and radio antennae may not be able to be used when the product is fitted.
- Do not modify this product.
- Refer to the maximum permitted load capacity specified in the fitting instructions. Do not exceed the vehicle manufacturers roof load rating if it is lower than the maximum load capacity specified in the fitting instructions.
- Loads should not overhang the sides of the product and be evenly distributed with the lowest possible centre of gravity.
- Long loads should be secured with non-elastic straps to the front and rear of the vehicle.
- Objects with pointed ends (e.g. ski poles) should be carried with the pointed ends to the rear of the vehicle.
- Remove all loose or removable objects from the load prior to loading.
- Make sure all loads are securely fastened with non-elastic straps. Check regularly during longer journeys.

- A loaded roof rack system can alter the performance of your vehicle. Be especially aware of the effects of side winds, changing of direction, and braking performance. Avoid rapid acceleration and deceleration. Drive carefully.
- Note that the total height of the vehicle increases when upright loads are carried.
- Products should be locked during transport if they have locks fitted.
- Check and replace worn out or defective parts.
- Keep the product clean and maintained.
- Never drive into a car wash with the roof rack system fitted.
- Lubricate locks and adjusting screws at regular intervals.
- Remove the products from the vehicle when not in use. Make sure all loose parts are stored safely.

- 
- Yakima Australia Pty Ltd  
17 Hinkler Court  
Brendale QLD 4500  
AUSTRALIA

[www.whispbar.com](http://www.whispbar.com)  
[www.whispbar.com.au](http://www.whispbar.com.au)  
[www.whispbar.co.nz](http://www.whispbar.co.nz)  
[www.whispbar.co.uk](http://www.whispbar.co.uk)  
[www.whispbar.co.za](http://www.whispbar.co.za)  
[www.whispbar.eu](http://www.whispbar.eu)  
[www.whispbar.ca](http://www.whispbar.ca)

---

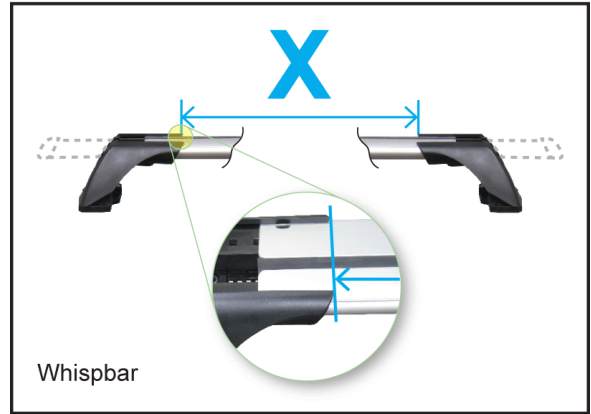
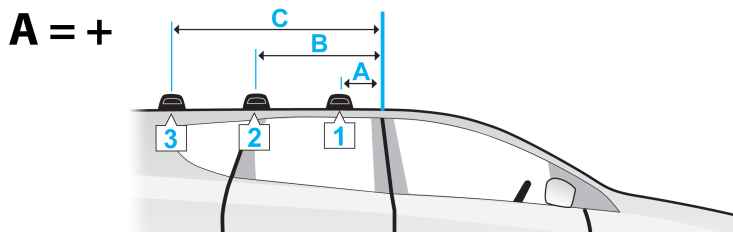
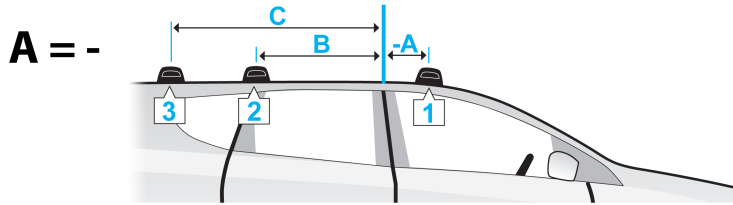

- Holden Combo XC, 5dr Van 01-+ (AU)
- Holden Combo XC, 5dr Van 01-+ (NZ)
- Opel Combo , 5dr Van 01- 11 (ZA)
- Opel Combo C, 5dr Van 01- 11 (EU)
- Vauxhall Combo C, 5dr Van 01- 11 (EU)

A	B	C	X		
			1	2	3
220mm	1040mm	-	910mm	915mm	-
8 11/16ths"	40 15/16ths"	-	35 13/16ths"	36 "	-
220mm	1040mm	-	910mm	915mm	-
8 11/16ths"	40 15/16ths"	-	35 13/16ths"	36 "	-
220mm	1040mm	-	910mm	915mm	-
8 11/16ths"	40 15/16ths"	-	35 13/16ths"	36 "	-
220mm	1040mm	-	910mm	915mm	-
8 11/16ths"	40 15/16ths"	-	35 13/16ths"	36 "	-