



Cruzber S.A., ES-A14018311
P.I. Las Salinas II, E-14960 Rute
www.cruzber.com

- (E)** Instrucción de montaje
¡Leer primero!
- (GB)** Assembly instructions
Read first!
- (F)** Instruction de montage
Lire en premier!
- (D)** Montageanleitung
Zuerst lesen!
- (PT)** Instruções de montagem
Ler primeiro!
- (PL)** Instrukcja montażu
Najpierw przeczytaj!
- (CZ)** Montážní návod
Čtěte pozorně!
- (HU)** Szerelési Utasítás
Először olvassd el!
- (RO)** Instrucțiuni de montaj
Întai citiți!
- (HR)** Detaljne upute
Prvo pročitati!
- (GR)** Διαβάστε προσεκτικά τις
Οδηγίες Συναρμολόγησης!
- (TR)** Öncelikli montaj:
Talimatlarını okuyunuz!
- (RU)** Инструкции по монтажу
Сначала прочитайте!
- (IT)** Istruzioni di montaggio
Leggere per primo!
- (NL)** Montagehandleiding
Eerst lezen!
- (SLO)** Navodila za sestavljanje
Preberite!

- Barras de acero
- Steel bars
- Barres d'acier
- Stahldachträger
- Barras d'aço
- Belki stalowe
- Ocelové strešní nosiče
- Acél rudak
- Čelične šipke
- Bare din otel
- Μπάρες Σιδερέ
- Çelik barlar
- Стальные поперечины
- Barre d'acciaio
- Stalen dakdragers
- Jeklene prečke

Código Code Code Kode	921-9xx								
Lv 7 2013 - r7									
Modelo Model Modèle Modell	SR+								
Lote Lot Lot Lot	<table style="display: inline-table; border: 1px solid black; text-align: center;"> <tr><td> </td></tr> <tr><td> </td></tr> <tr><td> </td></tr> <tr><td> </td></tr> </table> Peso Weight Poids Gewicht <table style="display: inline-table; border: 1px solid black; text-align: center;"> <tr><td> </td></tr> <tr><td> </td></tr> <tr><td> </td></tr> <tr><td> </td></tr> </table>								
Max: 75 kg									
Código Homologación CEE EEC Type Approval Number e9*74/483*87/354*3016									

1°
2°

- (E)** Contenido embalaje: ¡Verificar!
- (GB)** Package content: Check!
- (F)** Contenu d'emballage: Vérifier!
- (D)** Packungsinhalt: Überprüfen!
- (PT)** Contéudo embalagem: Verificar!
- (PL)** Zawartość opakowania: sprawdzić!
- (CZ)** Obsah balení: Zkontrolujte!
- (HU)** Csomag tartalma: Ellenőrizd!
- (RO)** Pachetul contine: Verificati!
- (HR)** Sadržaj paketa: Provjeri!
- (GR)** ΕΛΕΓΞΤΕ ΤΟ ΠΕΡΙΕΧΟΜΕΝΟ: ΤΟΥ ΠΑΚΕΤΟΥ!
- (TR)** Paket içeriğini: Kontrol ediniz!
- (RU)** Содержание упаковки: Проверьте!
- (IT)** Contenuto della confezione: Controllare!
- (NL)** Pakket inhoud: Controleer!
- (SLO)** Vsebina paketa: Preverite!

x 1	x 1	x 2	

Código Code		↔	kg	Lote Lot
921-932	SR+ 110	110 cm	4,05 kg	01/10
921-934	SR+ 120	120 cm	4,30 kg	01/10
921-936	SR+ 130	130 cm	4,55 kg	01/10
921-937	SR+ 135	135 cm	4,70 kg	01/10
921-938	SR+ 140	140 cm	4,98 kg	01/10
921-939	SR+ 150	150 cm	5,26 kg	01/10

Código
Code
Code
Kode

921-9xx

Lv 7 2013 - r7



Importante!
Important!
Important!
Wichtig!

- E** ¡Las barras tienen que usarse con sistemas de railing de techo homologados por el fabricante del vehículo!
- GB** Bars must be used with roof rails certified by cars manufacturer!
- F** Les barres devront être utilisées avec des railing de toit certifiés pour le fabricant du véhicule!
- D** Die Dachträger müssen mit einer vom Autohersteller geprüften Dachreling verwendet werden!
- PT** As barras devem ser utilizadas com rail de tejadillo homologado por o fabricante do veículo!
- PL** Belki muszą być stosowane z relingami certyfikowanymi przez producenta samochodu!
- CZ** Tento nosič musí být používán pouze na hagusy, které jsou schválené výrobcem vozidla!
- HU** A rudak csak a gyár által minősített hosszanti korláttal használható!
- RO** Barele transversale, trebuie utilizate cu bare longitudinale, agreate de producatorul autoturismului!
- HR** Šipke moraju biti korištene sa krovnim nosačem koji je certificiran od strane proizvođača automobila!
- GR** Οι μπάρες της CRUZ πρέπει να χρησιμοποιούνται σε κάθετες εργοστασιακές μπάρες πιστοποιημένες από τον κατασκευαστή του αυτοκινήτου
- TR** Barlar, araç üreticileri tarafından onaylanmış tavan çitaları ile kullanılmalıdır.
- RU** Поперечины должны быть использованы с рейлингами, сертифицированными производителем транспортного средства!
- IT** Le barre devono essere utilizzate unicamente con il sistema railing da tetto omologato dalla casa produttrice dell'auto
- NL** De dakdragers moeten worden gebruikt in combinatie met door de autofabrikant goedgekeurde dakrails!

1

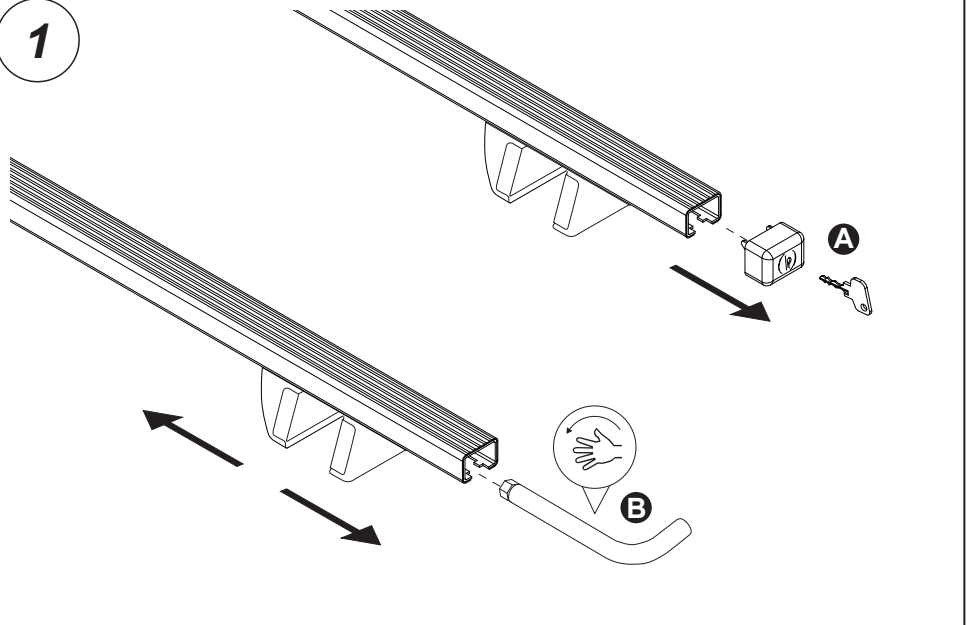

2

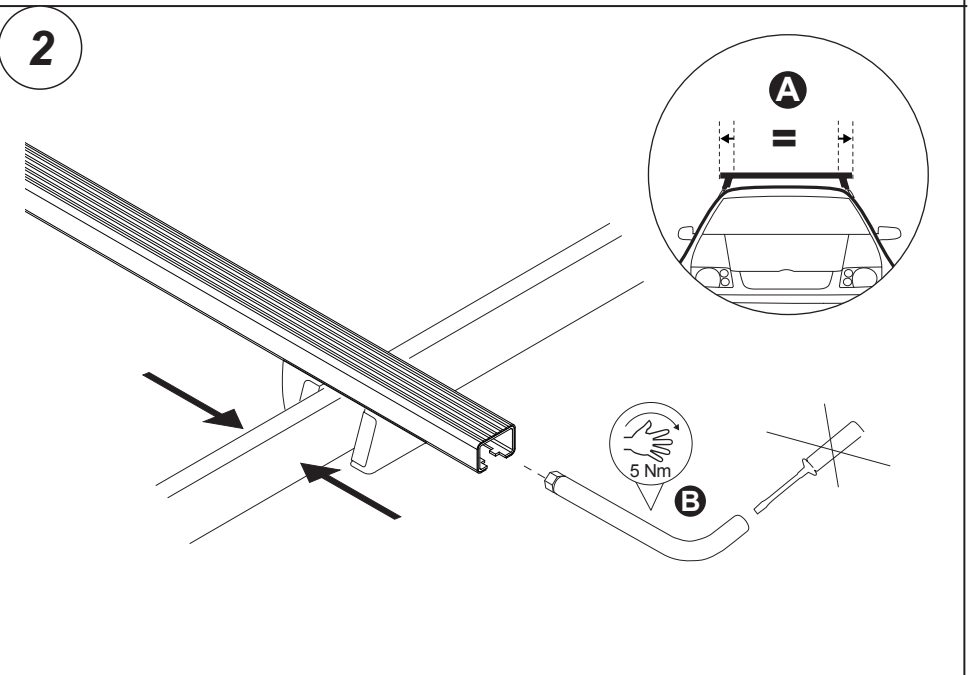

3

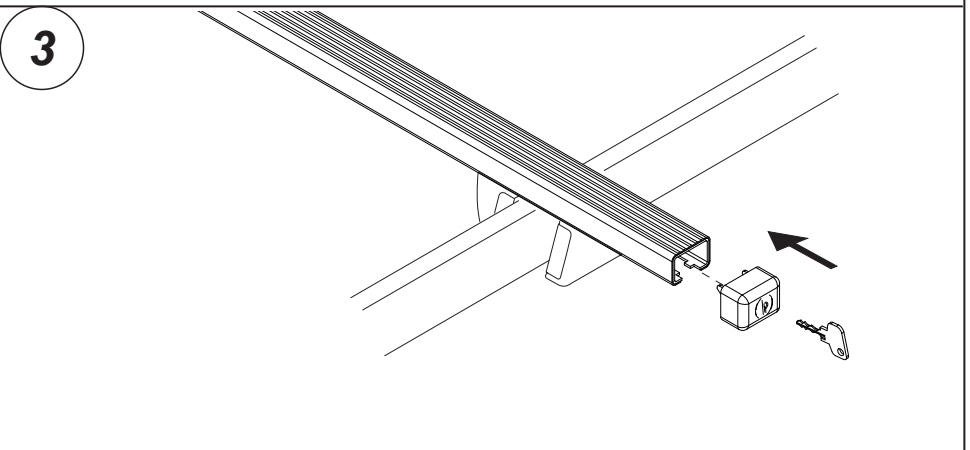

Optional
Optional

