



Cruzber S.A., ES-A14018311  
P.I. Las Salinas II, E-14960 Rute  
www.cruzber.com

Código  
Code  
Code  
Kode

**935-396**

Lv 7 2013 - r5

Modelo  
Model  
Modèle  
Modell

Lote	<b>01 -10</b>	Peso	<b>0,87 kg</b>
Lot		Weight	
Lot		Poids	
Lot		Gewicht	



**Max: 50 kg**

Kit tipo **A**  
Kit type  
Kit type  
Kit Typ

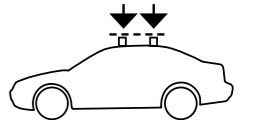

Código Homologación CEE  
EEC Type Approval Number

e9\*74/483\*87/354\*3017



Kit fijación

Fixation Kit

Kit fixation

Stützfuß-Kit

Kit fixação

Element mocujący

Fixační kit

Rögzítő készlet

Kit de fixare

Kit za montažu

Κιβώτιο (Kit) Επισκευής

Montaj kiti

Крепежный комплект

Kit di fissaggio

Bevestigingsset

Kit za pričvrstitev

**E Instrucción de montaje**  
¡Leer primero!

**GB Assembly instructions**  
Read first!

**F Instruction de montage**  
Lire en premier!

**D Montageanleitung**  
Zuerst lesen!

**PT Instruções de montagem**  
Ler primeiro!

**PL Instrukcja montażu**  
Najpierw przeczytaj!

**CZ Montážní návod**  
Čtěte pozorně!

**HU Szerelési Utasítás**  
Először olvasd el!

**RO Instrucțiuni de montaj**  
Intai cititi!

**HR Detaljne upute**  
Prvo pročitati!

**GR Διαβάστε προσεκτικά τις**  
Οδηγίες Συναρμολόγησης!

**TR Öncelikli montaj:**  
Talimatlarını okuyunuz!

**RU Инструкции по монтажу**  
Сначала прочитайте!

**IT Istruzioni di montaggio**  
Leggere per primo!

**NL Montagehandleiding**  
Eerst lezen!

**SLO Navodila za sestavljanje**  
Preberite!

**E Contenido embalaje:** ¡Verificar!

**GB Package content:** Check!

**F Contenu d'emballage:** Vérifier!

**D Packungsinhalt:** Überprüfen!

**PT Contéudo embalagem:** Verificar!

**PL Zawartość opakowania:** sprawdź!

**CZ Obsah balení:** Zkontrolujte!

**HU Csomag tartalma:** Ellenőrizd!

**RO Pachetul contine:** Verificati!

**HR Sadržaj paketa:** Provjeri!

**GR Ελέγξτε το περιεχόμενο:** του πακέτου!

**TR Paket içeriğini:** Control ediniz!

**RU Содержание упаковки:** Проверьте!

**IT Contenuto della confezione:** Controllare!

**NL Pakket inhoud:** Controleer!

**SLO Vsebina paketa:** Preverite!

x 1 	x 1 	x 1  (018-041)	x 1  (810-045)
x 4  1x (704-1434) 1x (704-1435) 1x (704-1436) 1x (704-1437)	x 4  2x (012-070) 2x (012-090)	x 1  (001-820)	

Código  
Code  
Code  
Code

**935-396**

Lv7 2013-r5



**! Importante!**  
**! Important!**  
**! Wichtig!**

- (E)** ¡Este Kit de fijación tiene que usarse con sistemas portacargas Cruz!
- (GB)** This fixation Kit must be used with Cruz roof rack systems!
- (F)** Cet Kit de fixation devra être utilisé avec les systèmes porte-charge Cruz!
- (D)** Dieser Stützfuß-Kit muß mit Cruz Dachträgersystemen benutzt werden!
- (PT)** Este Kit de fixação deve ser utilizado com os sistemas porta cargas Cruz!
- (PL)** Niniejszy element mocujący musi być używany z systemami bagażników dachowych firmy Cruz!
- (CZ)** Tento fixační kit musí být používán s nosným systémem Cruz!
- (HU)** Ez a rögzítő készlet csak a Cruz rendszerekkel használható!
- (RO)** Acest Kit de fixare, trebuie utilizat cu sisteme Cruz!
- (HR)** Kit za montažu mora biti korišten uz Cruz sistem krovnog nosača!
- (GR)** Το αξεσουάρ αυτό θα πρέπει να χρησιμοποιείται αποκλειστικά στα συστήματα μπαρών της Cruz!
- (TR)** Bu aksesuar mutlaka Cruz taşıma sistemleriyle kullanılmalıdır!
- (RU)** Крепежный комплект должен быть использован с багажной системой на крышу марки Cruz!
- (IT)** Questo kit di fissaggio deve essere usato con i portapacchi CRUZ
- (NL)** Deze bevestigingsset moet worden gebruikt in combinatie met Cruz dakdrager systeem!
- (SLO)** Kit za pričvrstitev naj se uporablja le z izdelki iz assortimana strešnih košar CRUZ!

1



2

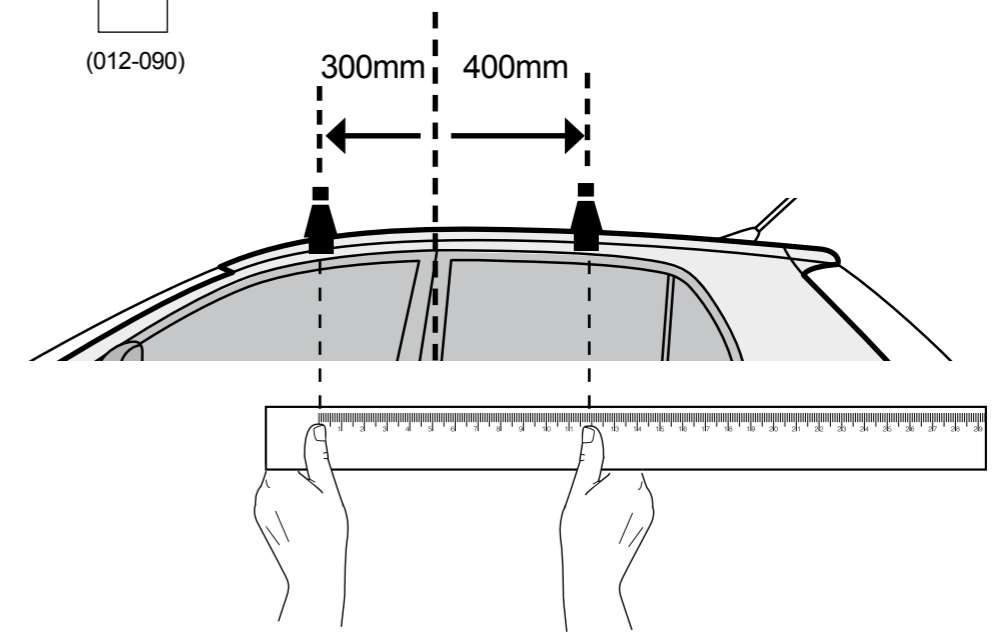
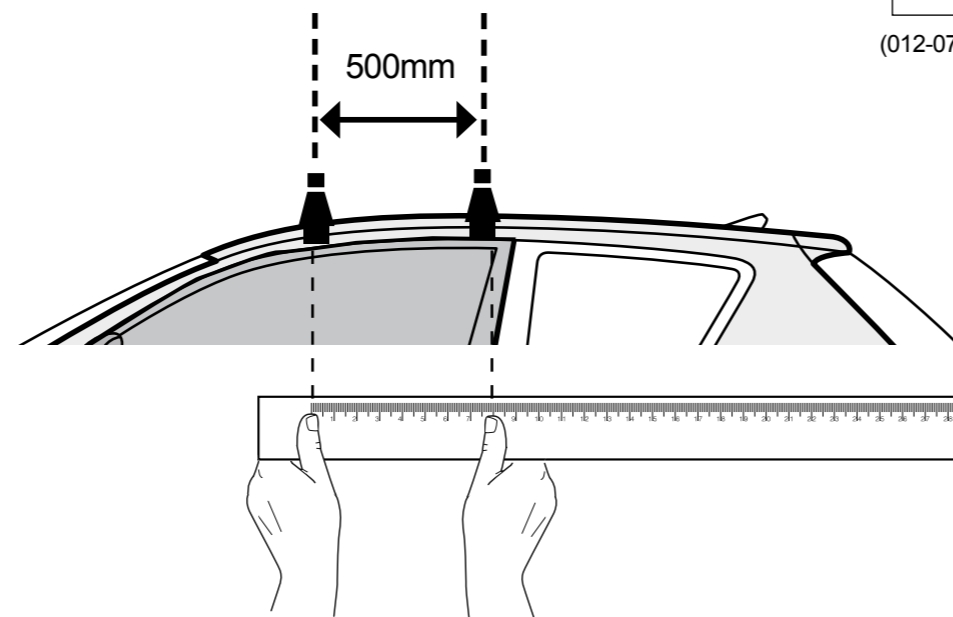
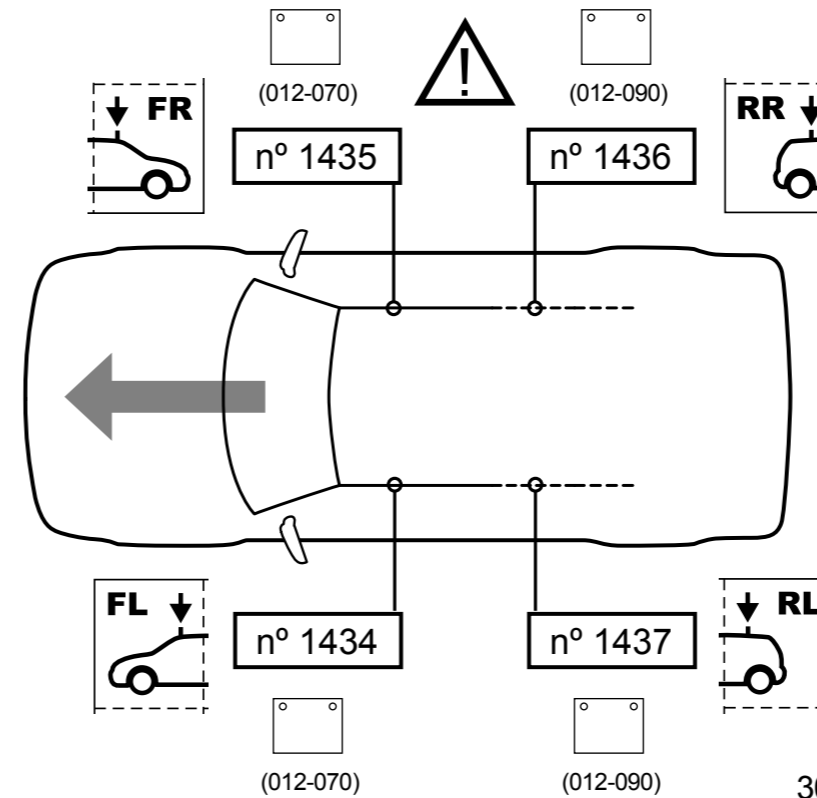
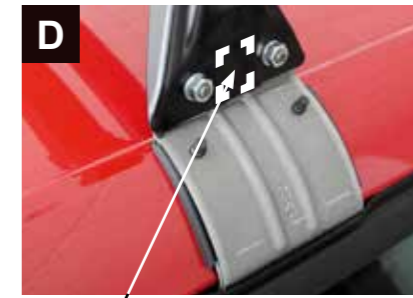
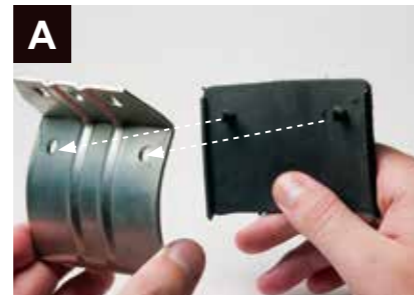

3

